

Digital Readouts

for Manually Operated
Machine Tools

HEIDENHAIN Digital Readouts for Manually Operated Machine Tools

Increased productivity with HEIDENHAIN digital readouts

By retrofitting your manually operated machine tools or measuring equipment with digital readouts from HEIDENHAIN, you've made a decision for increased productivity, higher precision and more operating ease.

Regardless of whether you're installing on new equipment or retrofitting machines already in operation, HEIDENHAIN digital readouts can easily be retrofitted to any model of machine or type of equipment, whatever the application and number of displayed axes.

Save time and reduce cost

A digital readout from HEIDENHAIN will save you valuable time. The distance-to-go function allows you to move swiftly to the next nominal position, simply by traversing to the display value zero. Or, you can use the multiple datum set function to enter position values quickly and without tedious calculation work.

To enable you to machine directly from the dimensions in your drawing, digital readouts offer the following support:

- Absolute/incremental dimensioning
- Radius/diameter switching (for lathes)
- Aids for fast datum setting

And POSITIP speeds up small-batch production – repetitive machining sequences can be saved as a program in POSITIP and used as often as you like.

HEIDENHAIN linear encoders for accurate positioning

HEIDENHAIN digital readouts work with HEIDENHAIN linear encoders, which are renowned for high accuracy and reliability. The linear encoders are sensors that directly record the movement of the axis slide and convert it into electrical measuring signals. These signals are evaluated by the display, which shows traverse paths and accurate positions as numerical values. Backlash in machine transfer elements does not affect the accuracy of the display.

Made-to-measure solutions

HEIDENHAIN offers digital readouts for every application – even for large traverses of 30 m and longer. Expert advice is provided by the competent staff at all HEIDENHAIN distributors. They are familiar with our wide product range and will find the optimal solution for your situation. You will find the retrofit agent closest to you on the back page of this brochure.



For HEIDENHAIN digital readouts in the Internet: www.positionsanzeigen.de

Contents

Practical Application Examples	4
Advantages of HEIDENHAIN Digital Readouts	6
HEIDENHAIN Display Units	
Overview	8
POSITIP 880: Display for max. 6 axes	10
The ND 700 Series: Displays for 2 and 3 Axes	12
The ND 200 Series: Universal 1-Axis Displays	14
Functions	
Convenient Datum Setting on Milling Machines	16
Convenient Datum Setting on Lathes	17
Features for Working with Lathes	18
Hole Patterns and Rectangular Pockets	19
Positioning with Distance-To-Go Display	20
Programming the POSITIP	21
HEIDENHAIN Linear Encoders	22
Return on Investment	28
Length Gauges from HEIDENHAIN	30
Cables	32
Dimensions Display Units and Linear Encoders	33



Milling



Grinding



Drilling



Eroding

HEIDENHAIN Digital Readouts at Work

HEIDENHAIN digital readouts have universal application: In addition to standard tasks on milling, drilling, boring machines and lathes, they also offer ideal solutions for many applications on machine tools, measuring and testing equipment, and special machines—in fact all machines where axis slides are traversed manually.

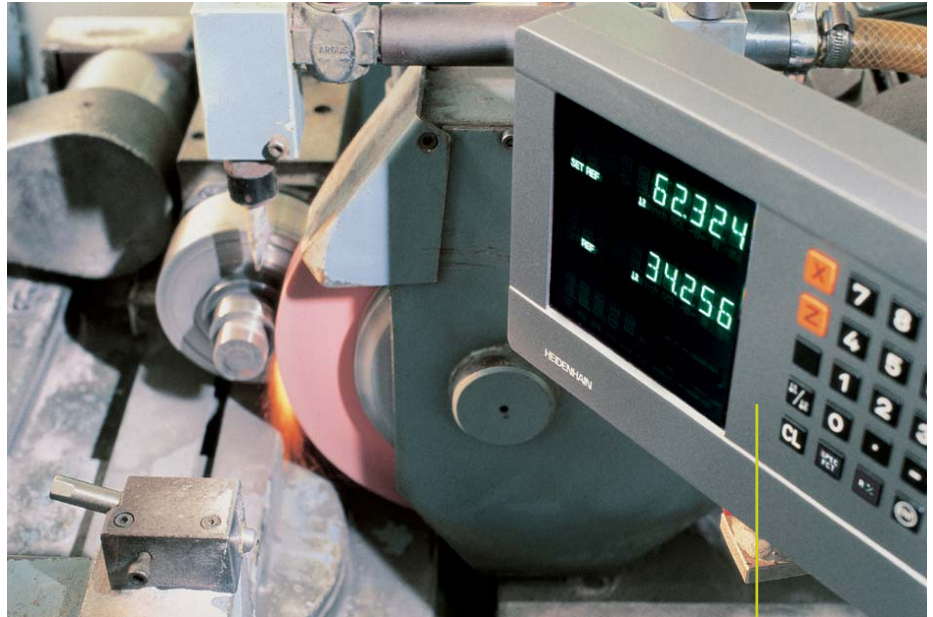

Circular grinding p. 12
ND 730 display unit
Linear encoders on X and Z: **LS 406 C**
Display step: 1 μm

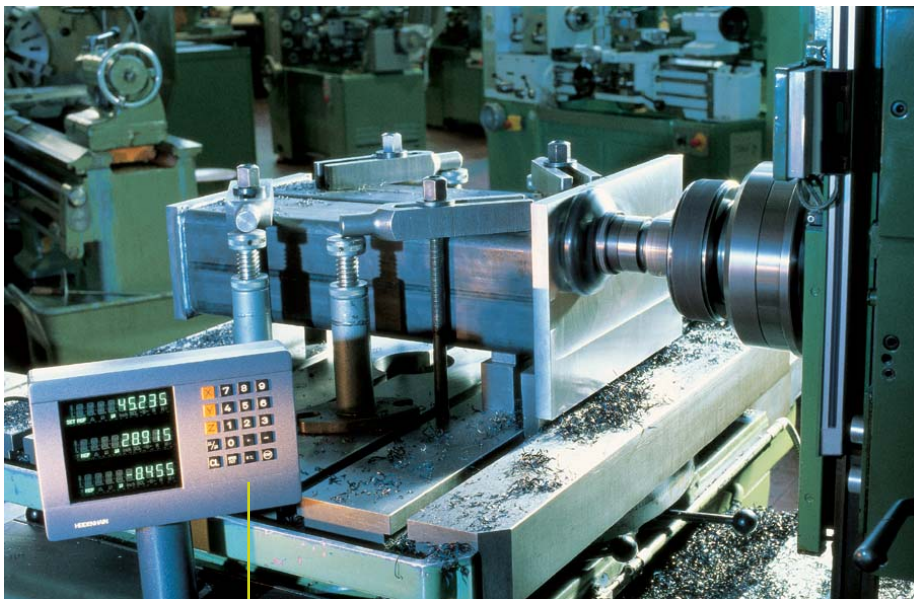

Milling p. 12
ND 760 display unit
Linear encoders on X and Y: **LS 603 C**,
On Z: **LS 303 C**
Display step: 5 μm



Drilling p. 10
POSITIP display unit
Linear encoders on X and Y: **LS 406 C**
Display step: 1 μm

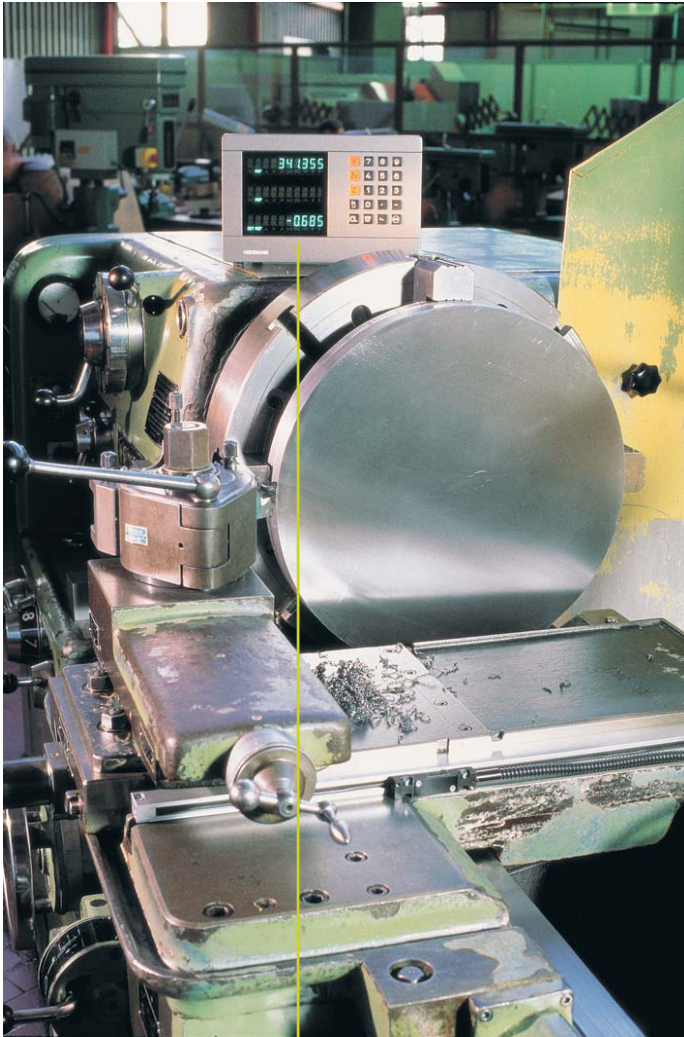

Turning p. 12
ND 770 display unit (sum display Z and Z₀)
 Linear encoders on X and Z₀: **LS 303 C**
 On Z: **LS 603 C**
 Display step: 5 µm

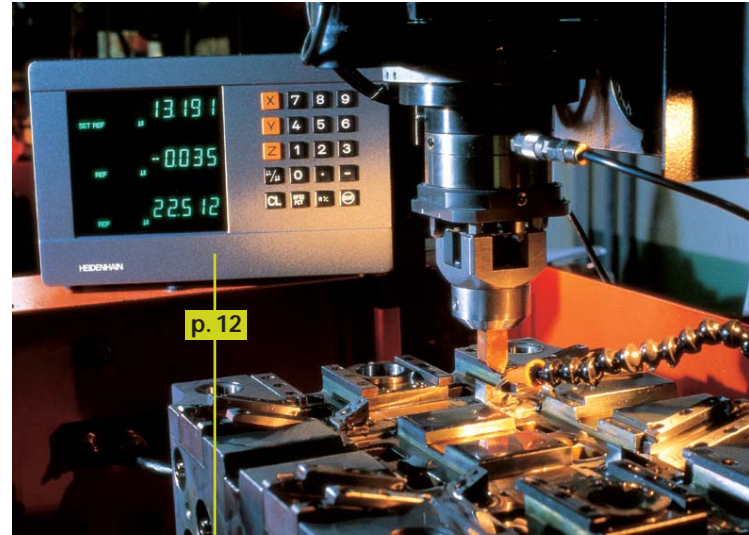

Eroding p. 12
ND 750 display unit
 Linear encoders on X and Y: **LS 106 C**
 On Z: **LS 406 C**
 Display step: 1 µm



Grinding p. 14
ND 221 B display unit
 Linear encoders on X and Y: **LS 406 C**
 Display step: 1 µm

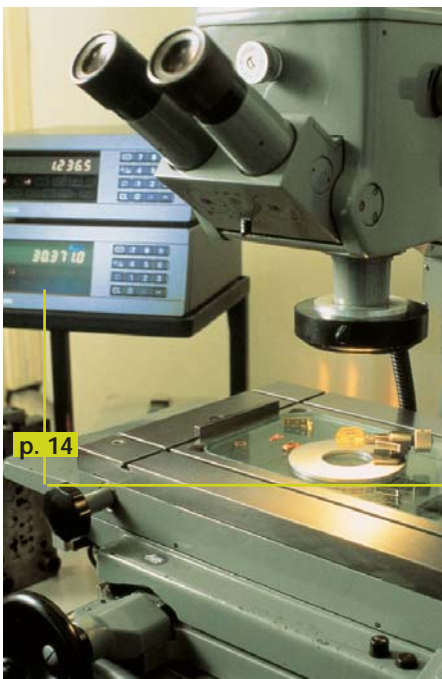

Measuring and inspection p. 14
ND 281 B display unit
 Linear encoders on X and Y: **LS 406 C**
 Display step: 0.5 µm

Advantages of HEIDENHAIN Digital Readouts

Fast

HEIDENHAIN's digital readouts save time. The distance-to-go display feature allows you to approach the next nominal position quickly and reliably, simply by traversing to a display value of zero. Datums can be set wherever you need them. This simplifies positioning, especially for workpieces with complicated dimensions.

When milling or boring hole patterns or rectangular pockets, the geometric data can be entered simply and quickly and the positions approached directly using the distance-to-go display.

On lathes, the sum display feature for saddle and top slide contributes to more accurate positioning. If taper dimensions are not complete, the position display will help you to calculate the angles.

The POSITIP is ideal for small-batch production, because repetitive machining sequences can be stored as programs and then used as often as you require.

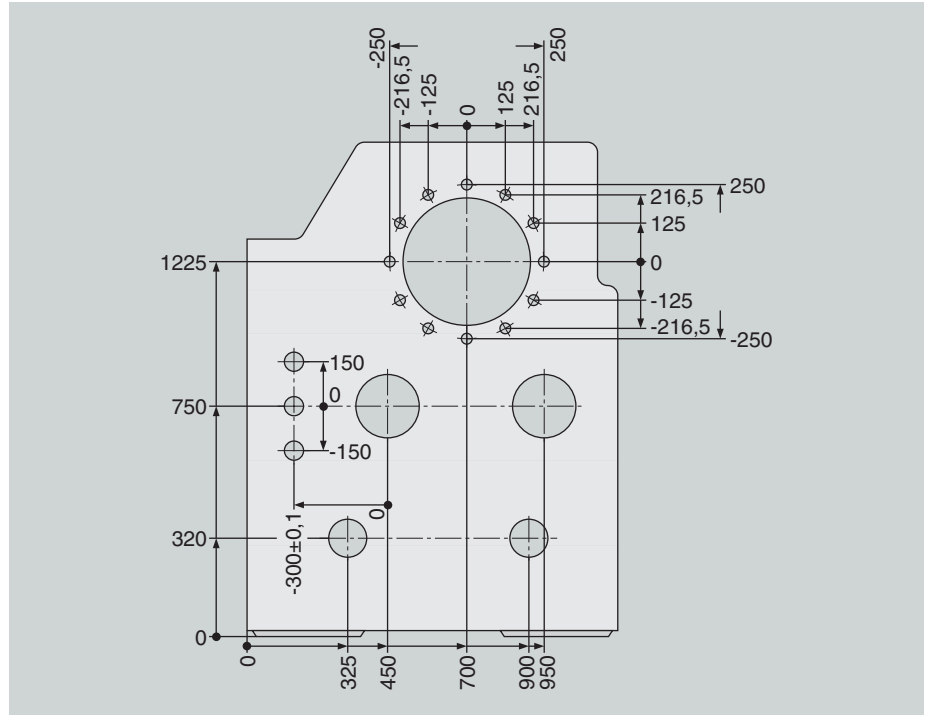

p. 10



Reliable

A highly readable display shows the measured positions referenced to the selected datum. As a result, the probability of error is reduced and machining becomes more reliable.

POSITIP's graphic positioning aid improves the speed and reliability of the distance-to-go display. Input of geometric data is made easy with the graphic display function.

Accurate

On older machine tools, precise machining in the range of 0.01 mm (0.0005 in.) is a matter of luck. Worn machine elements make exact dial and vernier settings impossible. Linear encoders from HEIDENHAIN sense machine slide movement directly, bypassing the backlash caused by mechanical transfer elements such as leadscrew/nuts, racks and gears. By determining the slide position directly, you achieve higher machining accuracy and reduce scrap rates.



ND 770

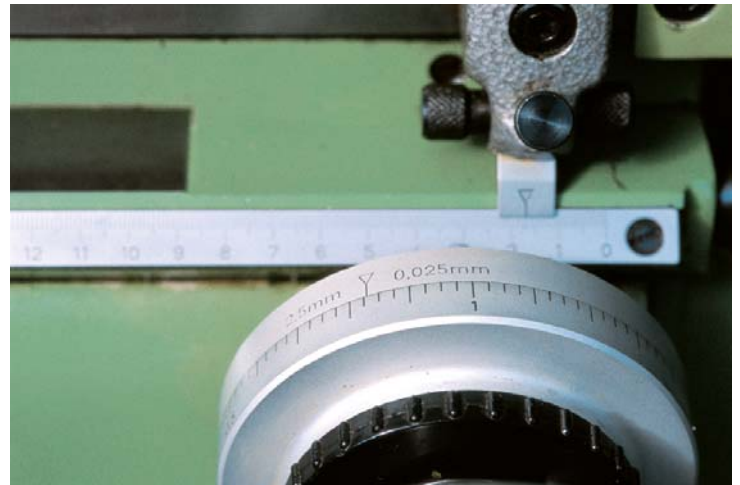

Vernier scales are no longer necessary if your machine is fitted with a HEIDENHAIN readout

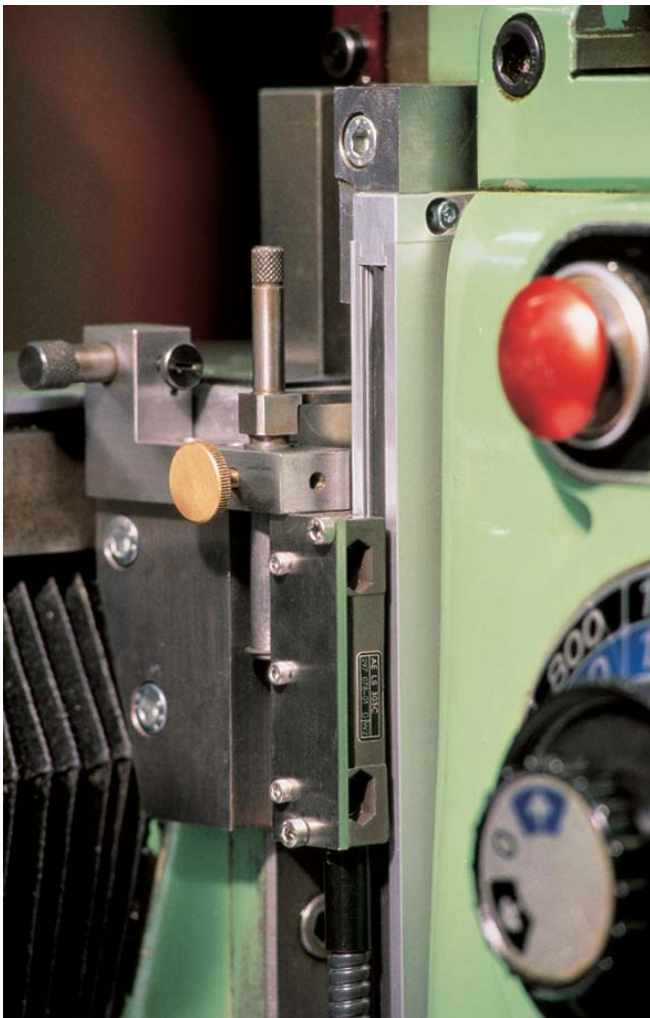

LS 303 C on the Z axis of a milling machine

Versatile, ergonomic, Well Designed: HEIDENHAIN Display Units

Digital readouts from HEIDENHAIN are designed with special emphasis on user friendliness.

Typical characteristics:

- Highly readable digital display.
- Simple, logically arranged keypad helps you quickly master the available functions and enter positions rapidly and reliably.
- Ergonomically designed push-button keypad with symbols that withstand years of use.
- Splash-protected front panel prevents damage to the display unit from coolant.

	POSITIP 880 Display with conversational guidance and contextual help on a flat screen; graphic features, program memory		ND 700 Series Displays with conversational guidance and advanced features	
Applications	Primarily for milling machines	Primarily for lathes	Primarily for milling machines	
Axes	POSITIP for milling up to 6 axes from A to Z	POSITIP for lathes up to 6 axes from A to Z and Z _O , Z _S	ND 710 X, Y ND 750 X, Y, Z	ND 720 X, Y ND 760 X, Y, Z
Display step	5 µm, 1 µm or finer		5 µm or 1 µm	5 µm, 1 µm or finer
Datums	99	1	2 (switchable to 9)	
Tool data	For 99 tools		For 1 tool	
Features	Probing functions for datum setting, primarily with the KT edge finder: "Edge," "Centerline" and "Circle Center"	<ul style="list-style-type: none"> • Radius/diameter display • Separate value or sum display Z_S for Z and Z_O 	Probing functions for datum setting with the tool: "Edge," "Centerline" and "Circle Center"	Probing functions for datum setting, primarily with the KT edge finder: "Edge," "Centerline" and
	Distance-to-go display with nominal position input in absolute or incremental values		Distance-to-go display with nominal position input in absolute values	
	Calculation and graphic display of hole pattern positions and rectangular pockets	Oversize allowance, Multipass cycle	Calculation and display of circular and linear hole patterns	
	Cutting data calculator	Taper calculator	-	
	Programming and storage of max. 999 program blocks per program		-	
Interface	RS-232-C/V.24, Centronics		-	RS-232-C/V.24



POSITIP



ND 700

- Sturdy cast-metal housing built for the worst of day-to-day workshop conditions.

		ND 200 Series Universal displays for 1 axis		
Primarily for lathes		Positioning devices, measuring and testing equipment, milling machines		
ND 730 X, Z ND 770 X, Z _O , Z		ND 221 B 1 axis	ND 281 B 1 axis	ND 282 B 1 axis
5 μm, 1 μm or finer		5 μm, 1 μm or finer		
1		2		
For 9 tools		-		
<ul style="list-style-type: none"> • Radius/diameter display • Separate value or sum display for Z and Z_O 		-	<ul style="list-style-type: none"> • Tolerance check, • min./max. evaluation from a series 	
		-		
-		-		
Taper calculator		-		
-		-		
-		RS-232-C/V.24	BCD	



ND 200

The POSITIP 880

The POSITIP 880 is a versatile display unit designed primarily for milling machines, boring machines and lathes with up to six axes. In addition to the features offered on the ND series displays, POSITIP offers advanced capabilities. It supports all operations with straightforward interactive menus on its large, easy-to-read flat screen. And it does it on big machines as well: Because the POSITIP 880 permits the connection of a separate display and control unit, you can have all position values and functions available at a second position.

Diverse functions—ease of operation

Soft keys enable POSITIP to offer a wide range of functions such as zero reset or entry in absolute or incremental dimensions. The functions of all soft keys are identified either with words (in the language of your country) or with easily understood symbols. Each operating mode, work step and screen display has individualized on-screen operating instructions, often with graphic illustrations, which can be called simply by pressing the HELP key. The INFO feature gives you additional on-screen support such as a pocket calculator, a stopwatch, a cutting data calculator for milling and a taper calculator for settings on the top slide for turning. The MOD key calls up user parameters such as radius/diameter switchover or separate/sum display of two axes.

Programs for small-batch production

The programming capabilities of POSITIP make it ideal for small-batch production on manual machine tools: up to 999 program blocks per program can be stored in its memory. Programs can be created either by keying them in step-by-step or generating them through actual position capture (teach-in programming). The subprogramming capability lightens your work load: repetitive machining sequences on the same workpiece only have to be entered once. Fixed cycles such as Bolt Hole Circle, Linear Hole Pattern or Rectangular Pocket (boring, milling) or Multipass (turning) keep your programs short and save you programming time.

p. 21

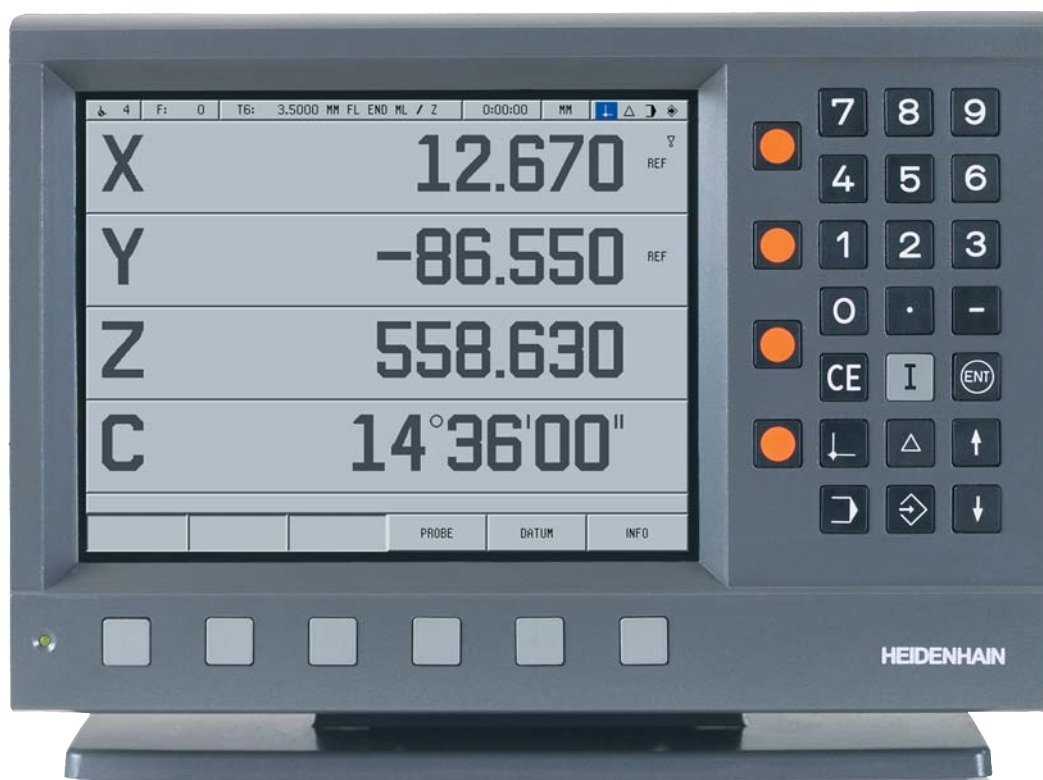

		POSITIP 880	
Application		Milling and boring machines	Lathes
Axes		Up to 6 axes from A to Z	Up to 6 axes from A to Z and Z ₀ , Z _S
Encoder inputs		11 μ A _{PP} , 1 V _{PP} or EnDat	
Display step		5 μ m, 2 μ m, 1 μ m (0.0002 in., 0.0001 in., 0.00005 in.) or finer, and 0.01° or finer	
Display		Color flat-panel display for position values, dialog and input, graphic functions, graphic positioning aid	
	Status display	Operating mode, REF, distance-to-go positioning cursor, inches, scaling factor, feed rate	
		Datum number, tool number and axis, tool radius compensation R-, R+, R0	Tool number, diameter display \varnothing , sum display
Features		<ul style="list-style-type: none"> • REF reference mark evaluation for distance-coded and single reference marks • Distance-to-go mode with input of nominal positions (absolute and incremental) • Contour monitoring with magnify function • Scaling • Any axis combinations • HELP: on-line operating instructions • INFO: pocket calculator, stopwatch 	
		<ul style="list-style-type: none"> • 99 datums, 99 tools • Probing functions for datum acquisition, primarily with the KT edge finder: "Edge," "Centerline" and "Circle Center" • Tool radius compensation • Calculation of positions for bolt hole circles and linear hole patterns • Positioning aids for rectangular pockets • INFO: cutting data calculator 	<ul style="list-style-type: none"> • 1 datum, 99 tools • Freezing the tool position for back-off • Oversize allowance • INFO: taper calculator
Programming		999 program blocks per program; subprogramming with rotation and mirroring; teach-in programming	
	Cycles	Line segments, circular arcs, chamfers, circular and linear hole patterns, rectangular pockets	Line segments, circular arcs, chamfers, multipass
Axis error compensation		Linear and multipoint linear with 128 compensation points	
Data interface	Serial	RS-232-C/V.24 ; 300 to 115 200 baud for output of programs, measured values and parameters; for downloading programs and parameters	
	Parallel	Centronics for measured value output	
Switching inputs and outputs		On request (over separate AMI input/output unit)	
Accessories		Tilting base, second operating unit	
		KT 130 edge finder	–
Power source		100 V to 240 V (–15% to +10%), 50 Hz to 60 Hz (\pm 2 Hz); power consumption 35 W	
Operating temperature		0° C to 45° C (32° F to 113° F)	
Protection (IEC 60529)		IP 40, front panel IP 54	
Weight		3.2 kg (7.1 lb)	

The ND 700 Series Displays

The ND 700 series consists of display units with special features for milling and boring machines (ND 710/ND 720 for two axes, ND 750/ND 760 for three axes) or for lathes (ND 730 for two axes, ND 770 for three axes).

These models all feature conversational programming to assist the machine operator with positioning tasks and explain the special display functions.

For positioning tasks, all models have a

p. 20

p. 16

distance-to-go display feature that allows you to quickly and reliably approach positions simply by traversing to a display value of zero.

With the ND 710 and ND 750 displays, it is possible to “freeze” tool position values to set the datum without using an edge finder. After touching the workpiece you can retract the tool to facilitate workpiece measurement.

The ND 720 and ND 760 displays also allow you to connect the KT edge finder from HEIDENHAIN (see “Datum Setting for Milling and Drilling”) and use the probing functions to locate 2 datum points.

The ND 710/750 and ND 720/760 are equipped with hole-pattern functions for milling, drilling and boring machines.

p. 19

The ND 730 and ND 770 display units for lathes include a tool memory for 9 tools whose data can be referenced to any datum point. To set the datums, touch the workpiece and freeze the tool position. Then retract the tool and measure the workpiece.

The ND 770 is the recommended choice if the lathe is equipped with a saddle and top slide: the sum display feature allows you to display the saddle and top slide either together or separately—at the touch of a key.



ND 760

	Primarily for milling and boring machines				Primarily for lathes	
	ND 710	ND 750	ND 720	ND 760	ND 730	ND 770
Axes	X, Y	X, Y, Z	X, Y	X, Y, Z	X, Z	X, Z ₀ , Z
Display	Axis positions (9 decades and sign), dialog and input display					
Status display	Active axis (SET), REF, distance-to-go Δ, inches, scaling factor SCL					
	Datum number, tool compensation R+, R- Probing functions				Tool number Radius/diameter	
					-	Separate or sum display for Z and Z ₀
Display step	5 μm or 1 μm		5 μm, 2 μm, 1 μm (0.0002 in., 0.0001 in., 0.00005 in.) or finer			
Features	<ul style="list-style-type: none"> REF reference mark evaluation for distance-coded or single reference marks Distance-to-go mode with input of nominal positions (absolute) Shrinkage compensation Freezing the tool position value for back-off 					
	• Tool radius compensation				-	
	• 2 datums (switchable to 9), 1 tool • Probing functions for datum acquisition with the tool: "Edge", "Centerline" and "Circle center"		• 2 datums (switchable to 9), 1 tool • Probing functions for datum acquisition, primarily with the KT edge finder: "Edge", "Centerline" and "Circle center"		• 1 datum, 9 tools	
	Calculating the position values for hole patterns (bolt hole circles, linear hole patterns)				Taper calculator	
Axis error compensation	Linear and multipoint over 64 compensation points					
RS-232-C/V.24 data interface	-		For output of programs and measured values		-	
Data transfer rates	-		110 to 38400 Baud		-	
Switching inputs	-		Two inputs: measured value output (pulse and contact)		-	
Accessories	-		KT edge finder		-	
	Tilting base					
Power source	100 V to 240 V (-15% to +10%), 50 Hz to 60 Hz (± 2 Hz); power consumption 15 W					
Operating temperature	0° C to 45° C (32° to 113° F)					
Protection (IEC 60529)	IP 40, front panel IP 54					
Weight	3 kg (6.6 lb)					

For One Axis: The ND 200 Series Universal Displays

The ND 200 series display units are designed for use with one linear encoder or length gauge. For simple positioning tasks such as infeed for a circular saw or press travel, as well as for

measuring and inspection stations, an ideal choice is the ND 221 B. Numerical position displays make it possible to transfer the measuring results over an RS-232-C interface to a PC or printer.

p. 30

For measuring tasks with special requirements such as sorting and tolerance checking or minimum/maximum display in a measurement series, HEIDENHAIN recommends the ND 281 B (with RS-232-C interface) and the ND 282 B (with BCD data output). The switching inputs and outputs of these two models permit their use also in simple automated environments.



ND 281 B

	Single-Axis Displays		
	ND 221 B	ND 281 B	ND 282 B
Display	Position values (9 decades and sign; ND 282 B: 8 decades)		
Status displays	REF, inches, datum 1, datum 2, SET datum setting		
	–	PRINT, MIN/MAX/DIFF/ACTL, START Sorting and tolerance checking (< = >)	
Display step	5 µm, 2 µm, 1 µm (0.0002 in., 0.0001 in., 0.00005 in.) or finer		
Features	<ul style="list-style-type: none"> • REF reference mark evaluation for distance-coded or single reference marks • 2 datums • Fast zero reset 		
	–	<ul style="list-style-type: none"> • Sorting and tolerance checking • Minimum/maximum display in a measurement series 	
Axis error compensation	Linear or multipoint over 64 compensation points		–
Data interface	RS-232-C/V.24		BCD
Data transfer rates	110 to 38400 Baud		–
Switching outputs for tasks in automation	–	<ul style="list-style-type: none"> • Zero crossover • Switching point 1 • Switching point 2 • Tolerance signal “<” • Tolerance signal “>” • Malfunction 	
Switching inputs for tasks in automation	–	<ul style="list-style-type: none"> • Zero reset • Preset • Measured value output, display freeze if necessary (pulse or contact) • External MIN/MAX selection • MIN display • MAX display • DIFF display • Start measurement series • Pass over reference mark • Inhibit reference pulse 	
Power source	100 V to 240 V (–15% to +10%), 50 Hz to 60 Hz (± 2 Hz); power consumption 8 W		
Operating temperature	0° C to 45° C (32° to 113° F)		
Protection (EN 60529)	IP 40, front panel IP 54		
Weight	1.5 kg (3.3 lb)		

Convenient Datum Setting on Milling Machines

Easy setup with probing functions

A very useful accessory for datum setting is the HEIDENHAIN KT edge finder: Simply move the edge finder toward a side of the workpiece until the stylus deflects. The counter automatically stores the exact position, taking into account the direction of approach and the radius of the stylus.

The milling machine displays

- ND 720, ND 760
- POSITIP 880

support the edge finder with the features

- Workpiece edge as datum
- Workpiece centerline as datum
- Circle center as datum

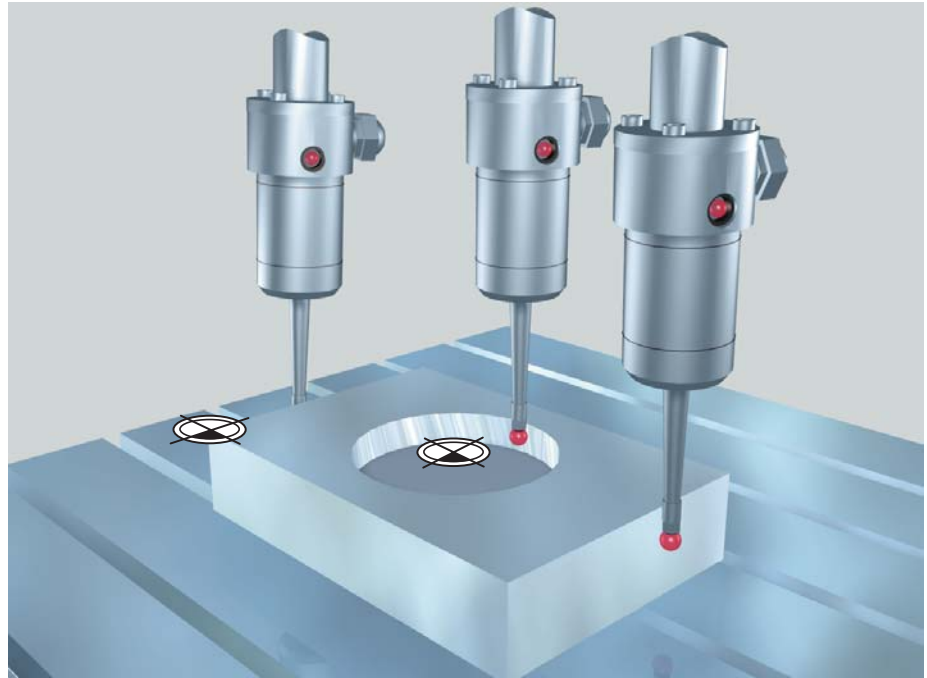

Accessory: KT edge finder

The KT is a 3-D triggering edge finder. The cylindrical stylus is spring-mounted in the edge finder housing. When the stylus contacts the workpiece, it is deflected and a trigger signal is sent over the connecting cable to an ND or POSITIP.

The KT edge finder allows you to set the datum quickly and easily, without leaving marks on the workpiece.

Datum setting with the tool

The probe functions can also be carried out with the tool. This is particularly relevant for the ND 710 and ND 750, which do not have a connection for an edge finder.

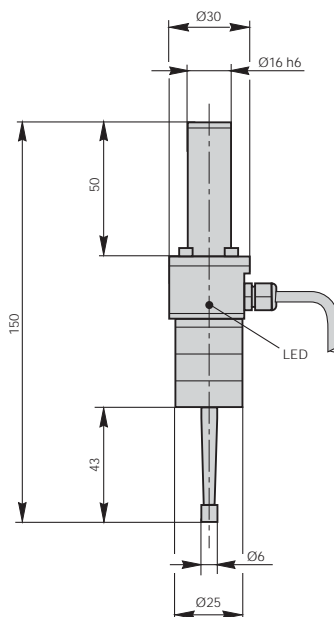

p. 10



p. 12

Convenient Datum Setting on Lathes

Determining and storing tool compensation values

With the ND 730, ND 770 (9 tools) and the POSITIP (99 tools) displays, you can store the dimensional data for the tools you insert in the turret or quick-change holder:

- Enter the tool position directly when turning the first diameter, or
- "Freeze" the current axis display value, retract the tool, measure the turned diameter and then enter that value.

Changing datums

If you change the workpiece or the workpiece datum, you can fix the new datum without having to change the stored tool-offset values. The tool data are automatically referenced to the new datum.

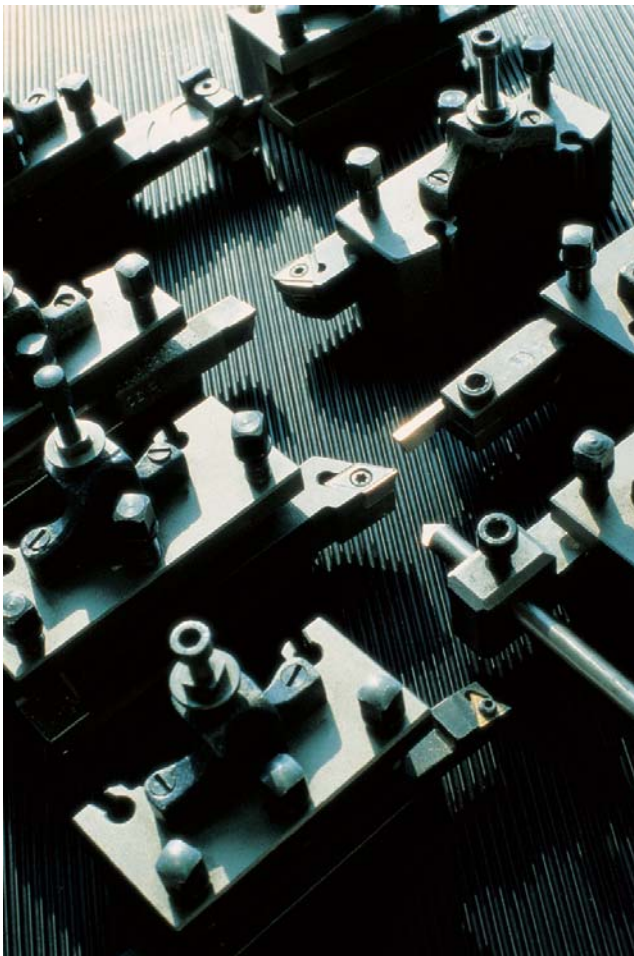
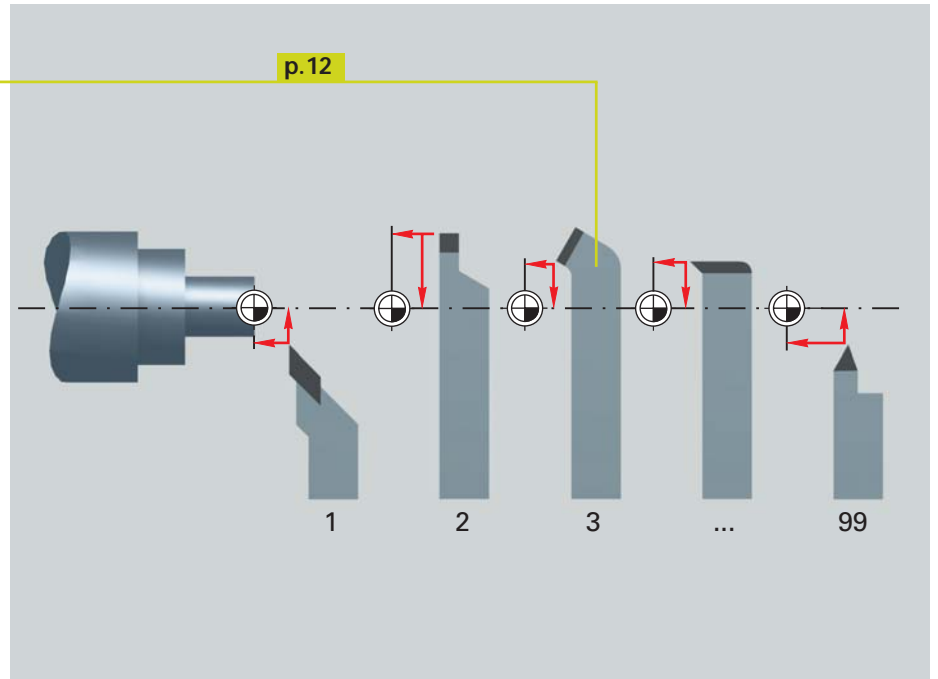

Features for Working with Lathes

Radius/diameter display

All lathe displays show the X-axis positions as either radius or diameter values. You can switch between displays using a keystroke.

Sum display of longitudinal axes

The ND 770 and POSITIP lathe displays can display the positions of the saddle and the top slide either separately or as the sum of both values.

- If you select **separate displays**, the position values are referenced to the datum for each individual axis. If only the saddle is moved, the displayed value for the top-slide axis remains unchanged.
- If **sum display** is selected, the counter adds both values. You can now read the absolute position of the tool in relation to the workpiece datum – without having to calculate!

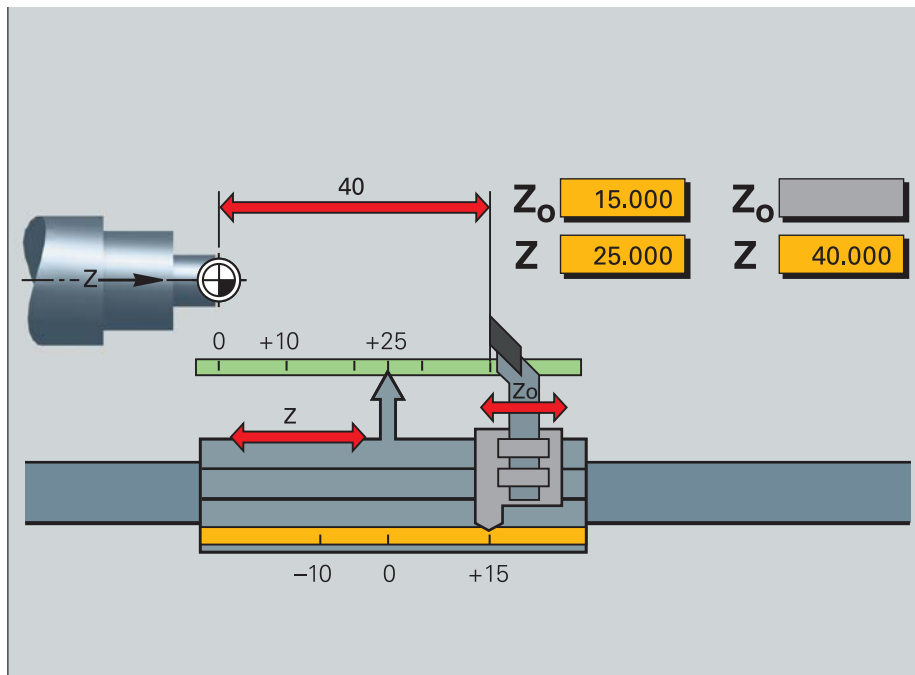

Taper turning made easy

If taper dimensions do not include the angle, POSITIP or the ND 730/ND 770 will help with the calculations. Simply enter the taper ratio or the two diameters and the length. POSITIP and ND 730/ND 770 will immediately display the correct angle for the top slide.

p. 10

TAPER CALCULATOR

DIAMETER 1

DIAMETER 2

LENGTH

ANGLE

The diagram shows a tapered shaft with a larger diameter on the left and a smaller diameter on the right. The taper is represented by a black trapezoidal shape.

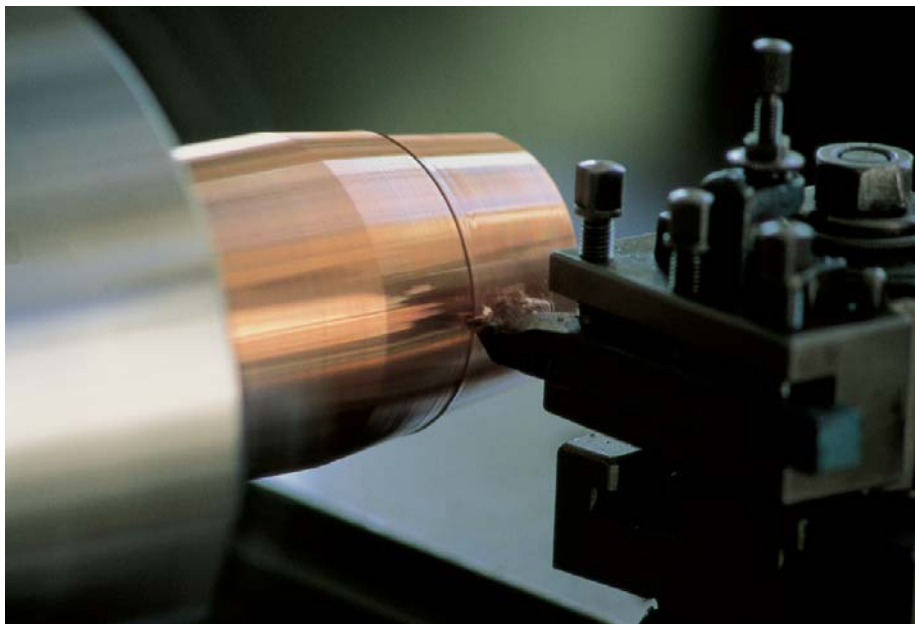

Multipass cycle

The POSITIP display unit features a cycle for turning a shoulder in several passes. The distance remaining to the target position is shown both in the longitudinal and tool axes. You decide on the best infeed increment.

Fast and Accurate Hole Patterns and Rectangular Pockets

Automatic calculation of bolt hole patterns for milling and drilling

With the milling machine displays series ND 700 and POSITIP you can produce bolt hole circles (full circles and circle segments) without a rotary table or linear hole patterns (rows or areas) without manual calculation.

Simply enter the geometric dimensions and the number of holes from the drawing, and the display calculates the coordinates of the individual holes in the working plane. You need only traverse "to zero" and drill—the display then shows you the next position.

The POSITIP also has a particularly useful feature: a graphic display of the programmed bolt-hole pattern lets you verify your input before machining.

p. 12

p. 10

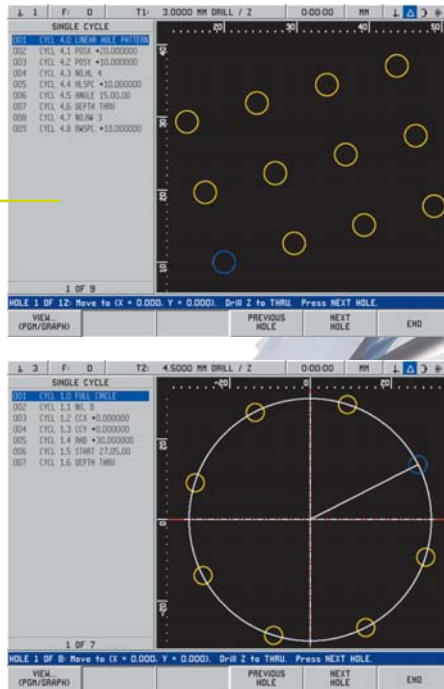
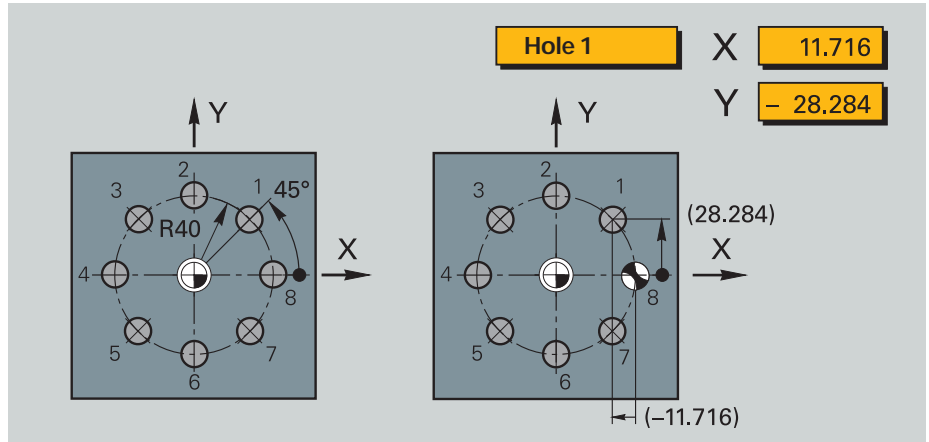

Milling and roughing-out rectangular pockets

The POSITIP aids you in milling and roughing-out rectangular pockets. The display unit calculates from your input the required positioning steps, and you simply traverse to the zero position value.

p. 10

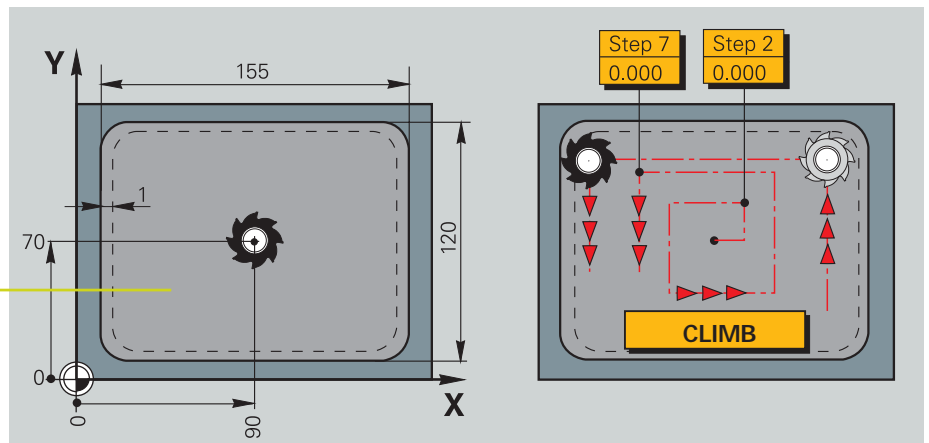

Easy Positioning with the Distance-To-Go Display and Contour Monitoring

Distance-to-go display for turning and milling

The distance-to-go display feature of the ND 700 series and POSITIP simplifies your work considerably. You enter the next nominal position, and the display shows you the distance remaining to the target position. You simply traverse to the display value zero.

The displays for milling can also compensate the cutter radius. You can machine your parts directly from the drawing dimensions without having to do any calculations, and there's no need to remember complicated numbers.

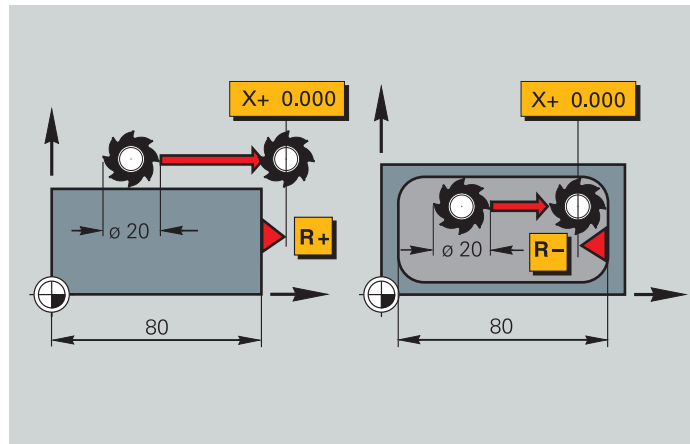

POSITIP's distance-to-go display

With POSITIP, offsets can be taken into consideration when turning. Simply enter the offset value and traverse to the display value zero using distance-to-go.

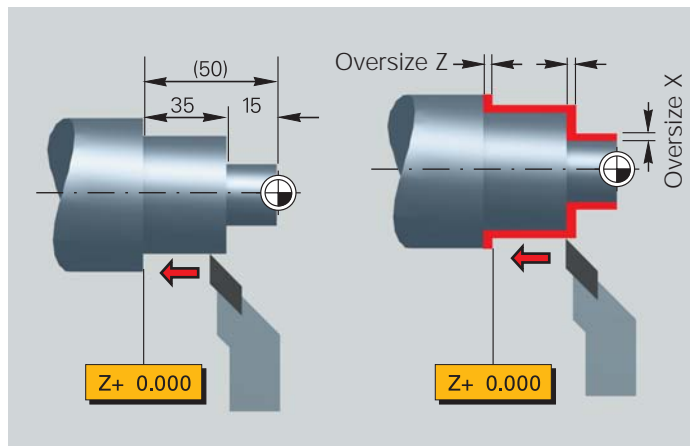

On POSITIP, the distance-to-go display is enhanced by a graphic positioning aid: As you traverse to zero, a square cursor moves into a target fork. If you prefer (e.g. for turning), POSITIP can show the absolute position value instead of the graphic.

p. 10



POSITIP: Contour monitoring for overseeing manual 2-D operations

Specially conceived for 2-D milling and turning work, the contour monitoring feature shows you whether the tool is still within the position tolerances that you have chosen. The magnify function makes this possible even for relatively narrow tolerances while a second window provides an overall view.

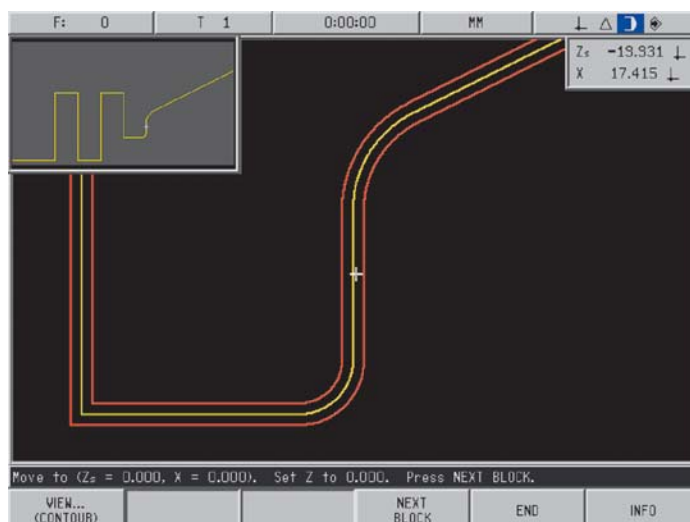

Programming Functions: Small-Batch Production Made Easy

p. 10

POSITIP's programming functions allow you to save repetitive machining steps. Thus for example you can save all of the machining sequences required for a small-batch workpiece as a program. In the programming mode of operation, the distance-to-go display will guide you step-by-step to the programmed positions.

Programs can be created either by keying them in step-by-step or generating them through actual position capture (teach-in programming).

POSITIP also allows you to generate program-section repeats and subprograms. If you are machining point patterns, you can program incremental positioning steps and then repeat them as often as necessary (program-section repeat). If you need to run the same program sequence at separate locations on the workpiece, you can write a subprogram and call it as needed. Both techniques save you time and reduce the chance of incorrect entries. In addition, fixed cycles such as Bolt Hole Circle, Linear Hole Pattern or Rectangular Pocket (boring, milling) or Multipass (turning) keep your programs short and save you programming time. In the course of your work, POSITIP presents each nominal position in the proper sequence. You need only move from one position to the next.

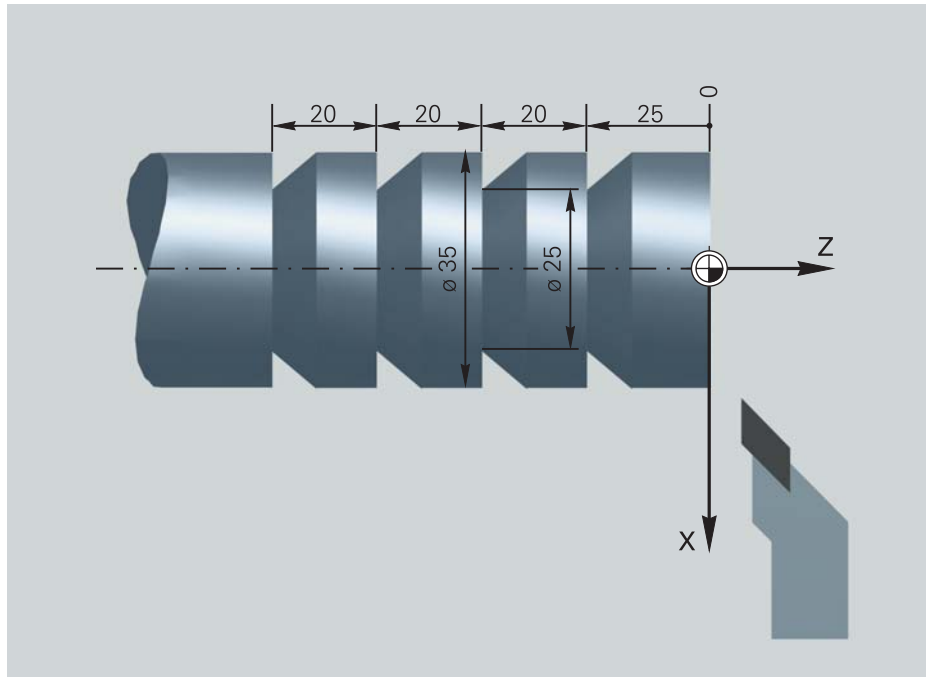
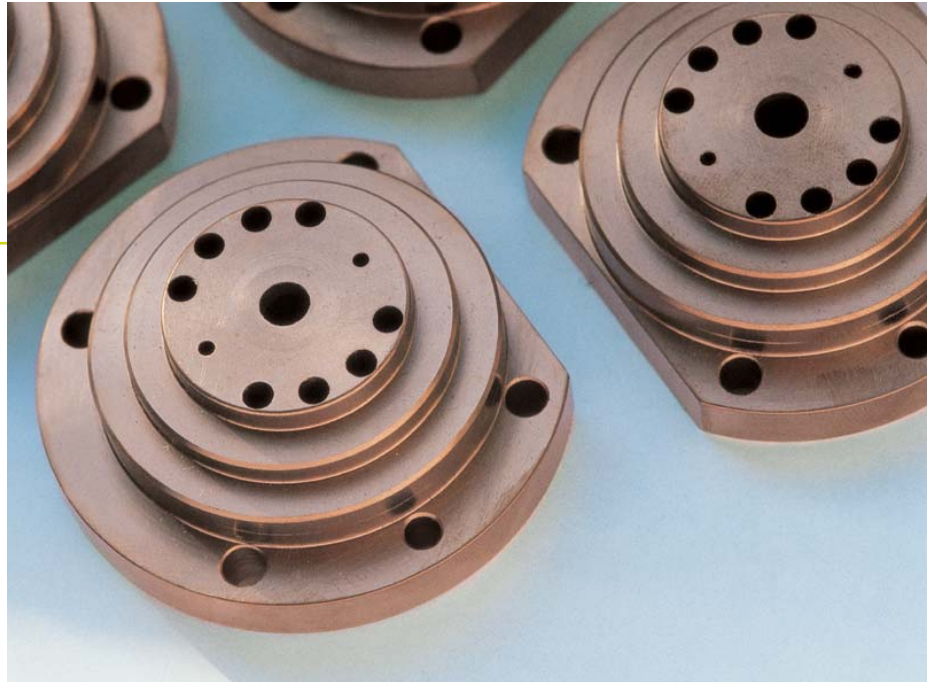

Example of a POSITIP program:
Multiple-recess turning on
one workpiece

```

000 BEGIN PGM 40 MM
001 X+80.000
002 Z+20.000
003 X+40.000
004 Z-5.000
005 LBL #8
006 IZ-20.000
007 X+25.000
008 X+40.000
009 CYCL 7.0 REPLBL 8 3/3
010 CYCL 7.1 OFFZ +0.000
011 CYCL 7.2 OFFX +0.000
012 X+80.000
013 END PGM 40 MM
    
```

They Determine the Accuracy: HEIDENHAIN Linear Encoders

HEIDENHAIN has a wide range of linear encoders to suit any application—for different display steps, installation spaces and traverse lengths.

The housing of the linear encoder is mounted onto the movable slide, and the mounting block is screwed onto the machine element that is stationary relative to the measured axis. Thus, the linear encoder measures the exact position of an axis directly at the axis slide. As a result, backlash in machine transfer elements,

spindle and gears has no effect on the measuring result, and spindle pitch error is not reflected in the measured position display.

The precision of the scale is the determining factor for the accuracy of the measurement: HEIDENHAIN linear encoders incorporate accurate scales or scale tapes. The scanning unit travels on a low-friction guide within the scale housing. It is connected to the external mounting block through a coupling that compensates the axial misalignment due to wear.

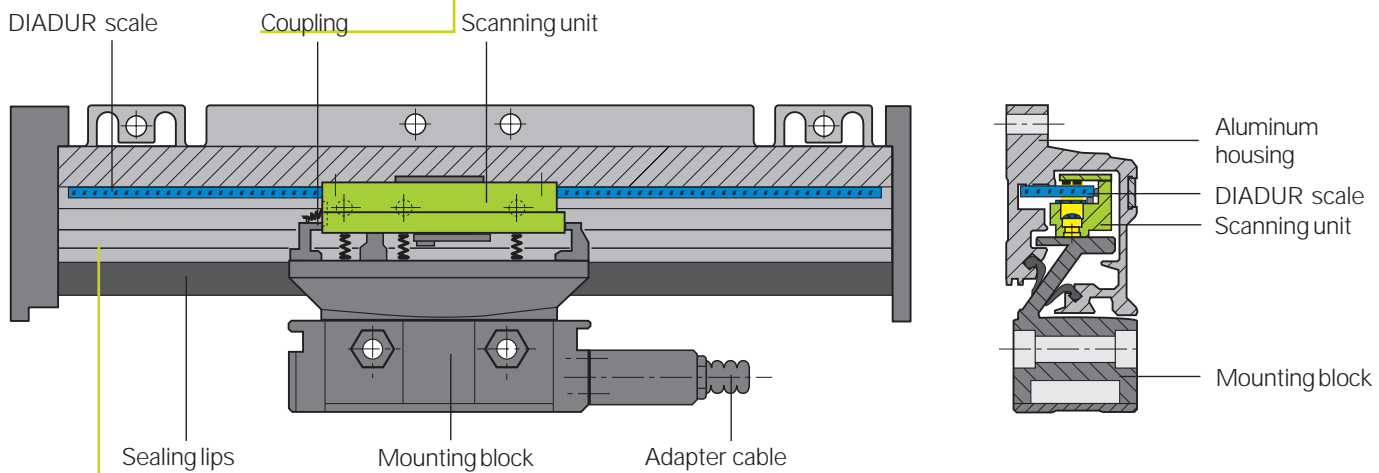

Robust design for years of service

HEIDENHAIN linear encoders are robust, vibration-resistant and durable.

The LS and LB linear encoders are sealed with an aluminum housing and flexible sealing lips at the bottom. This effectively protects them from chips, swarf, dirt and splashwater.

The photoelectric scanning of the LS and LB scales is a contact-free process, rendering the scales less subject to wear. The electrical wiring runs through the connecting web to the mounting block, then through a metal-armored cable with plastic cover to the display.

p. 24

p. 25

p. 26

Reference marks

The reference marks on the scale are required so that the display can show the correct position values after any intentional or unintentional interruption in power. With HEIDENHAIN digital readouts the procedure is very simple: by traversing the reference mark once in every axis you re-establish the assignment of display values to axis positions according to the datum as it was last defined. To save you having to traverse possible long distances after switch-on, HEIDENHAIN offers distance-coded reference marks on both LS and LB scales: after a maximum traverse of 20 mm (LS) or 80 mm (LB) in any direction the display value is automatically referenced to the last valid datum. Especially on machines with large traverses, this feature can bring you significant savings in time spent reproducing the datum points.

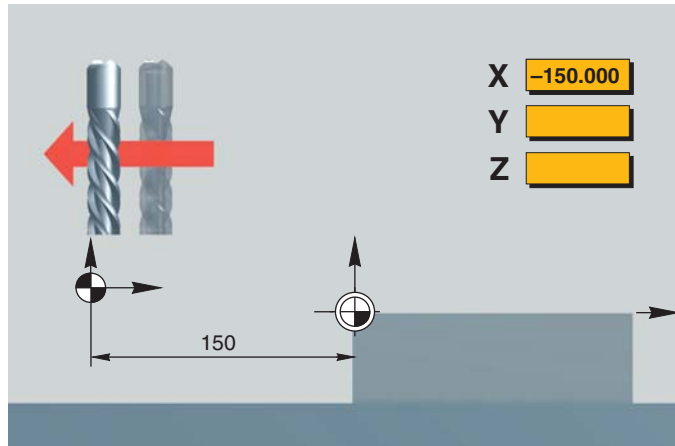

Datum setting

To set the datum, you must move the axes to some known point, such as a corner of the workpiece, from which all dimensions are to be measured. You then set the display values to zero or otherwise enter the values of the known position to define the assignment of display values to axis positions.

p. 16

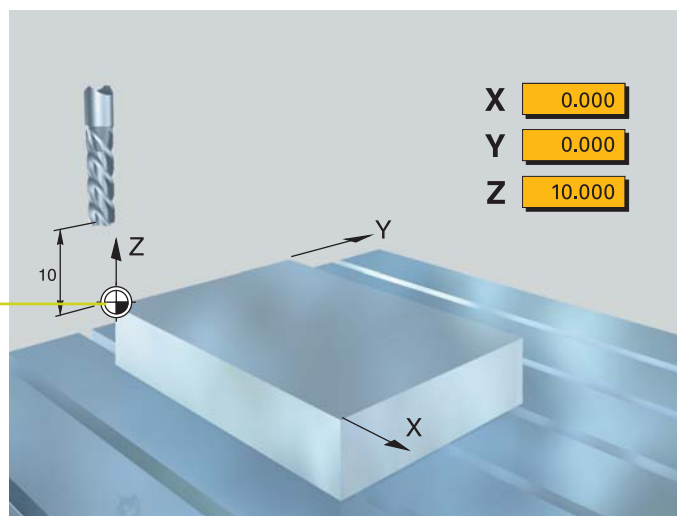
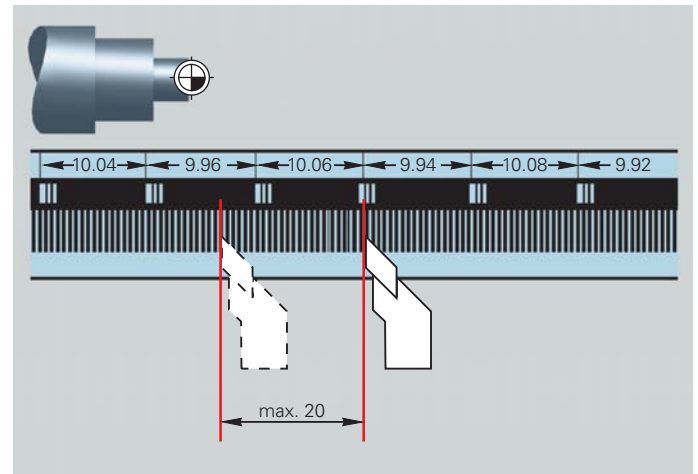

Incremental Linear Encoders

for Measuring Lengths up to 3040 mm (120 in.)

For typical applications on manual machine tools such as milling machines or lathes, **display steps of 10 μm or 5 μm** are sufficient. Such display steps are provided by the LS 303 and LS 603 linear encoders with an accuracy grade of better than $\pm 10 \mu\text{m}$ per meter traverse.

Jig boring machines, grinding machines, and measuring and inspection tasks normally require **display steps of 1 μm** and better. Linear encoders for these more stringent requirements typically feature accuracy grades of $\pm 5 \mu\text{m}$ per meter traverse.

For limited installation space, for example on the slide of a lathe, the LS 303 and LS 406 slimline linear encoders may be the best solution. They are available in measuring lengths up to 1240 mm (48 in.). When mounted with a back-up spar, these encoders are also available for measuring lengths up to 2040 mm (80 in.) and permit higher acceleration.

The **LS 603** and **LS 106** with full-sized scale housing function as universal linear encoders under **normal mounting conditions** for measuring lengths up to 3040 mm (120 in.).

LS 303

- Slimline scale housing for limited installation space
- Accuracy grade better than $\pm 10 \mu\text{m}$ per meter traverse

LS 303 without mounting spar



LS 406

- Slimline scale housing for limited installation space
- Accuracy grade better than $\pm 5 \mu\text{m}$ or $\pm 3 \mu\text{m}$ per meter traverse
- Defined thermal behavior

LS 406 with mounting spar



LS 603

- Universal linear encoder for normal mounting conditions
- Accuracy grade better than $\pm 10 \mu\text{m}$ per meter traverse
- Horizontal mounting possible



LS 106

- Universal linear encoder for normal mounting conditions
- Accuracy grade better than $\pm 5 \mu\text{m}$ or $\pm 3 \mu\text{m}$ per meter traverse
- Horizontal mounting possible
- Defined thermal behavior



	LS 303	LS 406	LS 603	LS 106
Scale housing	Slimline		Full size	
Accuracy grade	± 10 µm	± 5 µm or ± 3 µm to ML 1240	± 10 µm	± 5 µm or ± 3 µm
Measuring standard	Glass scale with DIADUR graduation; grating period 20 µm			
Measuring lengths ML in mm	70, 120, 170, 220, 270, 320, 370, 420, 470, 520, 570, 620, 720, 770, 820, 920, 1020, 1140, 1240, Only with mounting spar: 1340, 1440, 1540, 1640, 1840, 2040		170, 220, 270, 320, 370, 420, 470, 520, 570, 620, 720, 770, 820, 920, 1020	140, 240, 340, 440, 540, 640, 740, 840, 940, 1040
			1140, 1240, 1340, 1440, 1540, 1640, 1740, 1840, 2040, 2240, 2440, 2640, 2840, 3040	
Reference marks	LS 303, LS 406 Selectable by magnet every 50 mm; Standard setting: <i>ML 70 mm:</i> One reference mark at midpoint of ML; <i>up to ML 1 020 mm:</i> Two, each 35 mm from beginning/end; <i>from ML 1 140 mm:</i> Two, each 45 mm from beginning/end; LS 303C, LS 406C Distance-coded; for finding the absolute position value after max. 20 mm traverse		LS 603, LS 106 Selectable by magnet every 50 mm; Standard setting: One reference mark at midpoint of measuring length LS 603C, LS 106C Distance-coded; for finding the absolute position value after max. 20 mm traverse	
Max. traversing speed	120 m/min (4720 ipm)		60 m/min (2362 ipm)	120 m/min (4720 ipm)
Vibration IEC 60068-2-6 (55 to 2000 Hz)	≤ 100 m/s ² without mounting spar ≤ 200 m/s ² with mounting spar		≤ 30 m/s ²	≤ 200 m/s ²
Shock IEC 60068-2-27 (11 ms)	≤ 300 m/s ²		≤ 200 m/s ²	≤ 400 m/s ²
Required moving force	≤ 5 N		≤ 10 N	≤ 4 N
Type of protection IEC 60529	IP 53 when mounted as per instructions IP 64 with compressed air			
Operating temperature	0 to 50 °C (32 to 122 °F)			
Weight	0.4 kg + 0.4 kg/m ML		0.7 kg + 2 kg/m ML	0.2 kg + 2.6 kg/m ML
Power supply	5 V ± 5 % < 100 mA			
Output signals	~ 11 µA _{pp} ; signal period 20 µm			
Electrical connection	Separate adapter cable (1 m/3 m/6 m/9 m) with or without armor (see <i>Cables and Pin Layouts</i>)			
Permissible cable length to subsequent electronics	30 m (98.5 ft) max.			

Incremental Linear Encoders for Large Traverses

On large boring or milling machines, but also on lathes with long Z axes, traverse ranges can extend three meters and more. HEIDENHAIN has the proper linear encoders for such special applications.

The **LB 302** universal linear encoder with full-size scale housing is designed for accuracy better than $\pm 5 \mu\text{m}$ per meter measuring path for display steps of $10 \mu\text{m}$, $5 \mu\text{m}$ and $1 \mu\text{m}$. In measuring lengths from 440 mm to 3040 mm it is supplied as a single-section, complete encoder. For **measuring lengths** from 3240 mm to **30 040 mm**, the housing is assembled from sections and the single steel scale tape is then pulled into its slot.

The **LIM 501** magnetic linear encoder is intended for reduced accuracy requirements, such as on the Z axes of lathes. It permits a display step of $10 \mu\text{m}$ at an accuracy of better than $\pm 100 \mu\text{m}$ per meter traverse. Measuring lengths up to 2040 mm are available as single-section, complete units. For larger **measuring lengths up to 28 040 mm**, the housing is assembled on the machine from sections and a single scale tape is inserted.

LIM 501

- For large measuring lengths up to 28 m (92 ft)
- Accuracy grade better than $\pm 100 \mu\text{m}$ per meter traverse
- For limited installation space



LB 302

- For large measuring lengths up to 30 m (100 ft)
- Accuracy grade better than $\pm 5 \mu\text{m}$ per meter traverse
- Defined thermal behavior
- With linear machine error compensation
- Two mounting positions



	LB 302	LIM 501
Scale housing	Full size	Slimline
Accuracy grade (per meter traverse)	± 5 µm	± 100 µm
Measuring standard	Stainless steel strip with AURODUR graduation; grating period 40 µm coefficient of thermal expansion: α_{therm} 10 ppm/K	Magnetized plastic layer on steel support tape grating period 10.24 mm
Measuring length ML in mm in 200 mm steps	440 mm to 3040 mm Single-section encoders, complete 3240 mm to 30040 mm Kit with single-section AURODUR scale tape and housing sections	440 mm to 2040 mm Single-section scale 2240 mm to 28040 mm Kit with single-section scale tape
Reference marks	LB 302 Every 50 mm by selector plates; Standard setting: One reference mark at midpoint LB 302C Distance-coded; for finding the absolute position value after max. 80 mm traverse	Every 10.24 mm by magnets
Max. traversing speed	120 m/min (4720 ipm)	600 m/min (23 620 ipm)
Vibration IEC 60068-2-6 (55 to 2000 Hz)	≤ 300 m/s ²	≤ 200 m/s ²
Shock IEC 60068-2-27 (11 ms)	≤ 300 m/s ²	
Required moving force	≤ 15 N	–
Protection IEC 60529	IP 53 when installed as per instructions IP 64 with compressed air	IP 64
Operating temperature	0 to 50 °C (32 to 122 °F)	
Weight	1.8 kg + 3.3 kg/m ML	0.25 kg + 0.375 kg/m ML
Power supply	5 V ± 5 % < 100 mA	5 V ± 5 % < 150 mA
Output signals	~ 11 µA _{PP} ; signal period 40 µm	~ 11 µA _{PP} ; signal period 10.24 mm
Electrical connection	Separate adapter cable (1 m/3 m/6 m/9 m) connectable to mounting block (see <i>Cables and Pin Layout</i>)	Cable (3 m) with metal armor tubing and connector
Permissible cable length to subsequent electronics	30 m (98.5 ft) max.	



Better, Faster, More Efficient

Digital readouts from HEIDENHAIN provide greater ease of operation in your production. That means user friendliness that, aside from the greater convenience, also increases your productivity—both on standard machine tools and in very special applications:

- You machine parts according to the data given on the drawing, without calculations. Why? Because you can choose whether to work with incremental or absolute dimensions, with several datums if necessary, in millimeters or inches.
- You can read the exact tool position at all times. This reduces machine idle time while preventing scrap and reworking.

Return on investment within a few months

Example: Milling machine with 3 axes

• Cost of HEIDENHAIN linear encoders and ND 700 display, including installation:	U.S. \$2500 (approx.)
• Increase in production and profit:	Min. 20 %
• Hours of operation:	160h/month
• Machine cost per hour:	\$40/hour
• Saving in production costs:	$\frac{20\% \cdot \$40}{100\%} \cdot \frac{160\text{ h}}{\text{month}} = \frac{\$1280}{\text{per month}}$
• Payback period:	$\frac{\$2500}{\$1280/\text{month}} = 2\text{ months}$

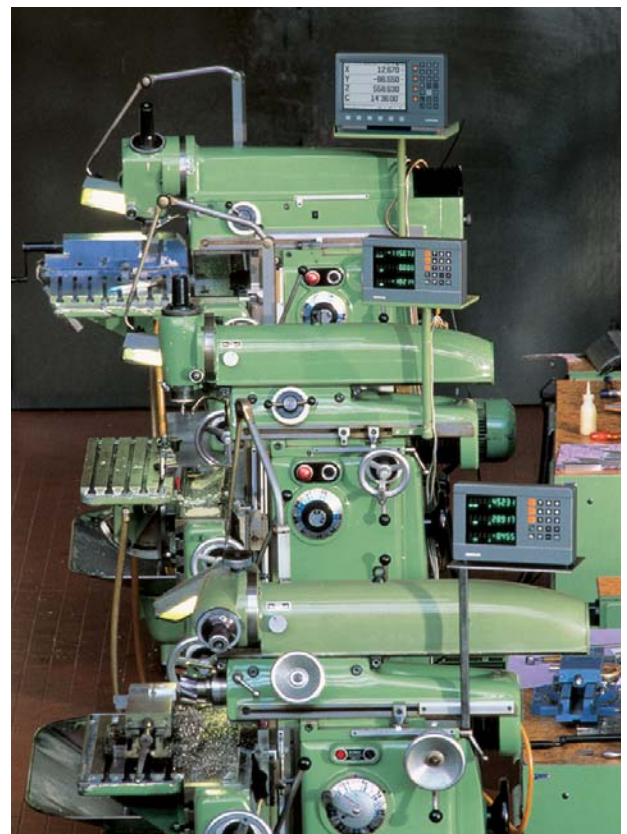
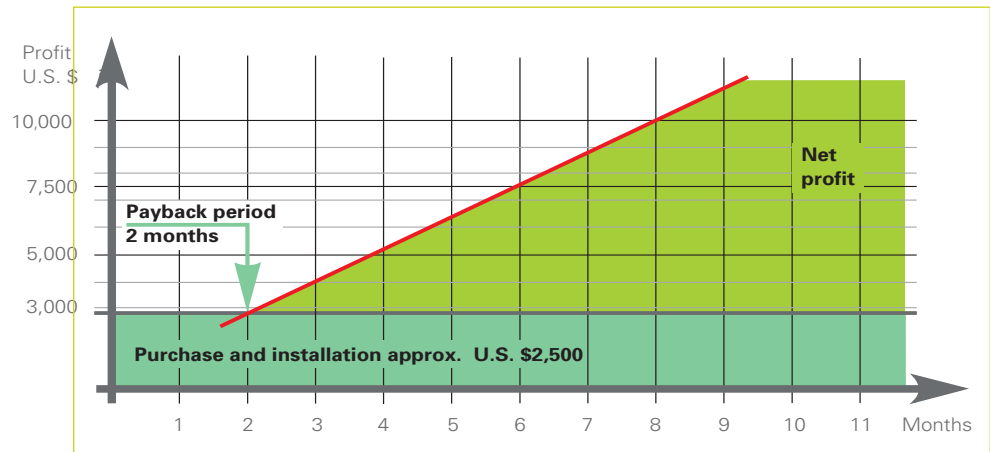

Incremental Length Gauges from HEIDENHAIN: Measuring Equipment for the Workshop

Incremental length gauges from HEIDENHAIN offer high accuracy over long measuring ranges. They feature well-thought-out design characteristics in sturdily made models for industrial use.

They have a wide range of applications in production metrology, in multipoint inspection stations, measuring equipment and as position measuring devices.

Fast on-site inspection

Installing inspection apparatus near your machine means that you will be able to monitor changes on your machine—caused by tool wear or thermal expansion—and react to correct them on time. Because of the large traverse ranges and the simple use of the length gauges as well as the accurate and clear digital displays, HEIDENHAIN length gauges are an optimal choice for universal, fast and accurate measurements at your machining location.

Quality of the finished workpieces is guaranteed

The HEIDENHAIN METRO MT length gauges are characterized by high accuracy: $\pm 0.2 \mu\text{m}$ (for traverses of 12 mm and 25 mm), $\pm 0.5 \mu\text{m}$ (for traverses of 60 mm) or $\pm 1 \mu\text{m}$ (for traverses of 100 mm). An individual calibration chart is included with each length gauge. Thus a reference to the national standard is guaranteed and the length gauges can be used for certification of the finished workpieces.

The CT 2500 length gauges (25 mm traverse) and CT 6000 (60 mm traverse) from the HEIDENHAIN CERTO program are available for the increased accuracy of $\pm 0.1 \mu\text{m}$.



With their small dimensions and measuring ranges of 12 mm or 30 mm and $\pm 1 \mu\text{m}$ accuracy, the HEIDENHAIN SPECTO length gauges are specifically designed for multipoint inspection devices.

The measured value displays of the ND 200 series are suitable for typical applications in quality assurance.

- Checking the dimensional accuracy of workpieces is simple with the sorting and tolerance check function. The display unit compares the current meas-

ured value with an upper and a lower limit value previously entered via the keyboard. The result of the evaluation (whether the measured value is below, above or within tolerance) is indicated in the status display with different symbols. In addition, a corresponding signal is available at the switching outputs.

- The measuring results can be output to a printer for documentation purposes or a PC for further processing via the **RS-232-C/V.24 data interface**.

Further information

For more detailed product information, see our *Length Gauges* brochure.





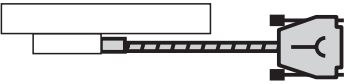

p. 14

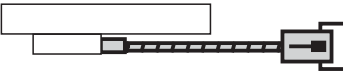

Cable

For PT 880	LS 106, LB 302	LS 303, LS 406	LS 603
Adapter cable with D-sub connector (female) 	368 178-xx	368 179-xx	–
	Cable length 1 m/3 m/6 m/9 m		
	Cable diameter 6 mm		
Adapter cable with metal armor, with D-sub connector (female) 	–	367 321-xx	368 605-xx
	Cable length 1 m/3 m/6 m/9 m		Cable length 1 m/3 m/6 m
	Cable diameter 10 mm		

For ND 700 and ND 200	LS 106, LB 302	LS 303, LS 406	LS 603
Adapter cable with connector (male) 	310 130-xx	310 125-xx	310 573-xx
	Cable length 1 m/3 m/6 m/9 m		
	Cable diameter 6 mm		
Adapter cable with metal armor, with connector (male) 	310 129-xx	310 124-xx	310 731-xx
	Cable length 1 m/3 m/6 m/9 m		Cable length 1 m/3 m/6 m
	Cable diameter 10 mm		

Connecting cable PUR Ø 8 mm [3(2 x 0.14 mm ²) + (2 x 1.0 mm ²)]	
Complete with coupling (female) and connector (male) 	309 774-xx
Complete with metal armor coupling (female) and connector (male) 	309 775-xx
Complete with coupling (female) and D-sub connector (female) 	368 172-xx
With one coupling (female) 	309 780-xx
With one connector (male) 	309 776-xx
Cable only 	244 955-01

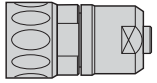
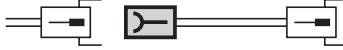
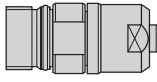
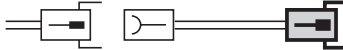
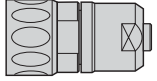
Connecting element on encoder 	Cnnctr. (male), 9-pin 
For encoder cable Ø 4.5 mm Ø 6 mm	291 697-02 291 697-03
Mating element on connecting cable to the encoder connector, 9-pin 	Coupling (female), 
For connecting cable Ø 8 mm	291 698-01
Connector on connecting cable to subsequent electronics 	Cnnctr. (male), 9-pin 
For connecting cable Ø 8 mm	291 697-04

Dimensions

Position Display Units

POSITIP 880

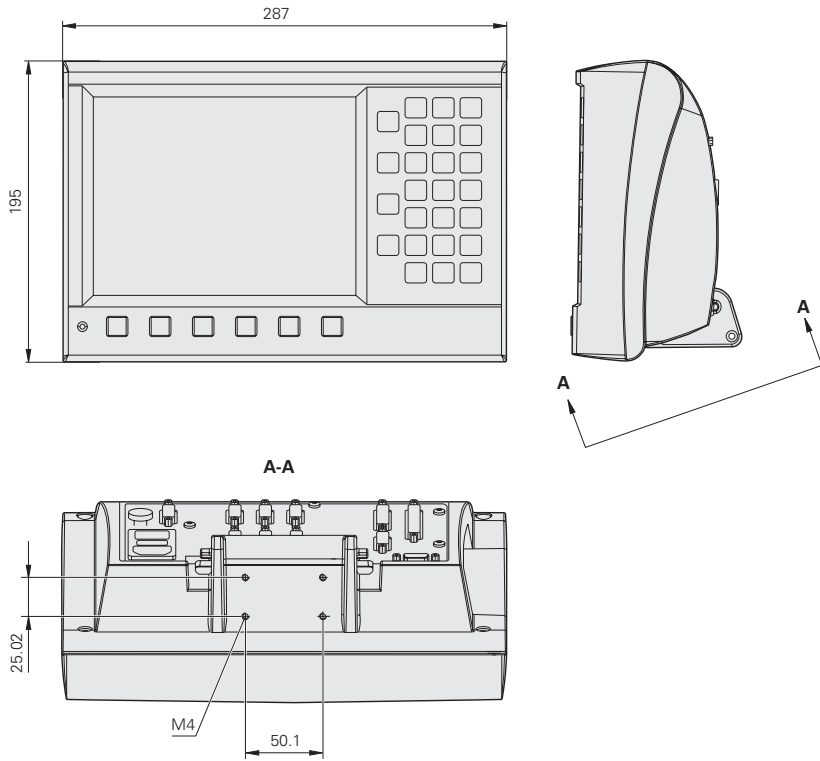

ND 700 Series

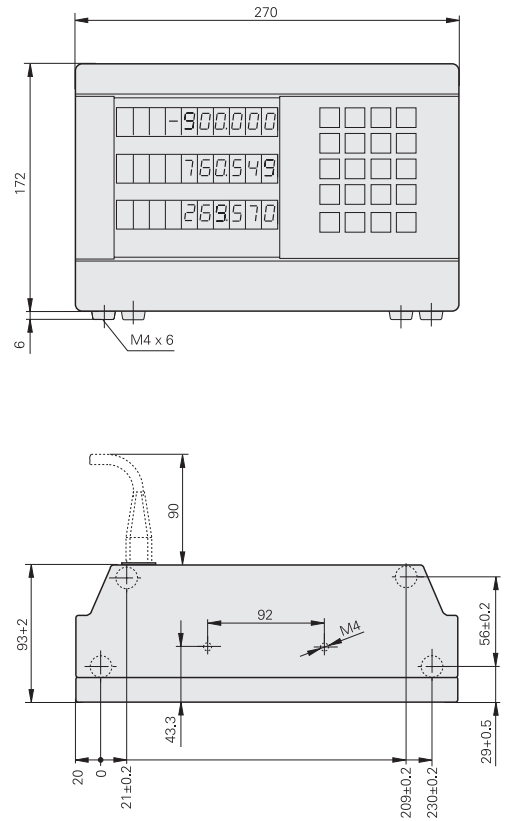

Tilting base for PT 880

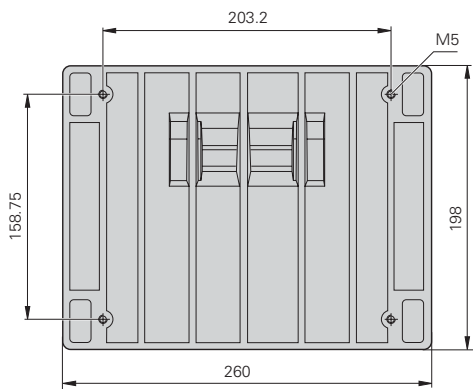

ND 200 Series

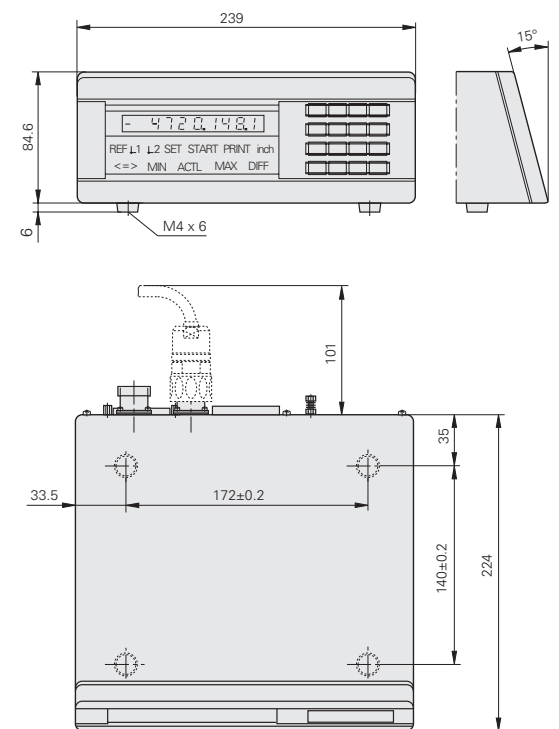

Tilting base for ND 700

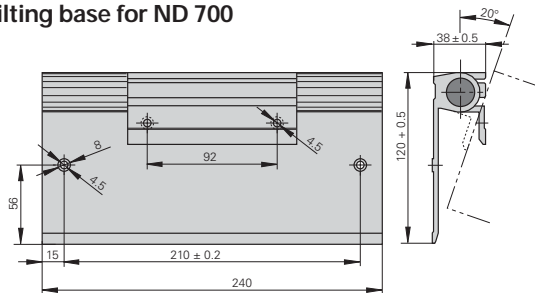

Dimensions
in mm



DIN ISO 8015
ISO 2768 - m H

LS 303

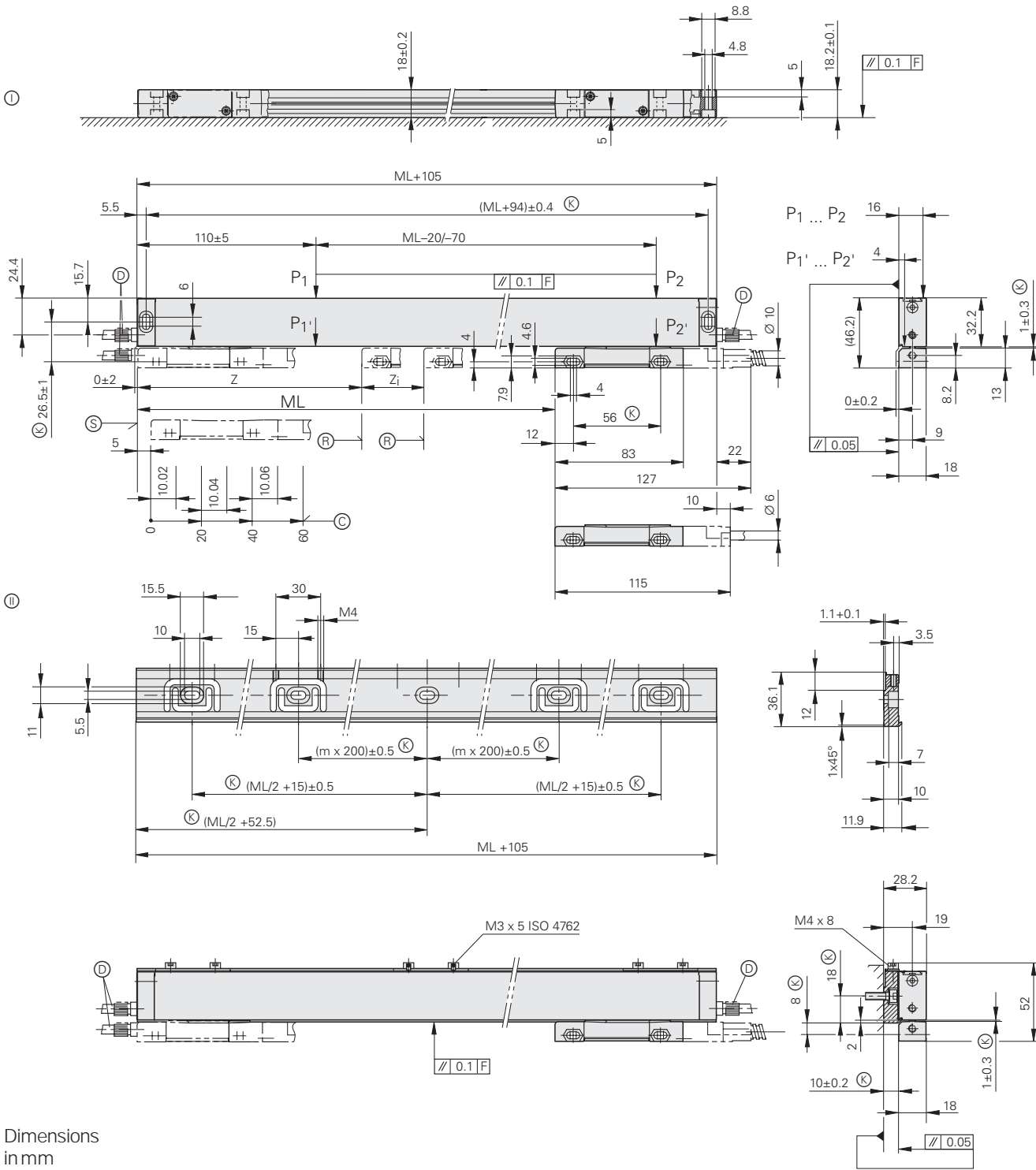

Dimensions
in mm



DIN ISO 8015
ISO 2768 - m H

Mounting spar

ML	m
70 ... 520	0
570 ... 920	1
1020 ... 1340	2
1440 ... 1740	3
1840 ... 2040	4

- Ⓐ = Scanning unit with permanent cable
- Ⓑ = Scanning unit, cable connectible
- ① = Without mounting spar
- ② = With mounting spar
- F = Machine guideway
- P = Gauging points for alignment
- Ⓚ = Required mating dimensions
- Ⓞ = Compressed air inlet

- Ⓞ = Reference mark position on LS 303
- Two reference marks for measuring lengths
- | 70 ... 1020 | 1140 ... 2040 |
|--------------------|--------------------|
| $z = 35$ mm | $z = 45$ mm |
| $z_1 = ML - 70$ mm | $z_1 = ML - 90$ mm |
- Ⓞ = Reference mark position on LS 303 C
 - Ⓞ = Beginning of measuring length (ML)

LS 406

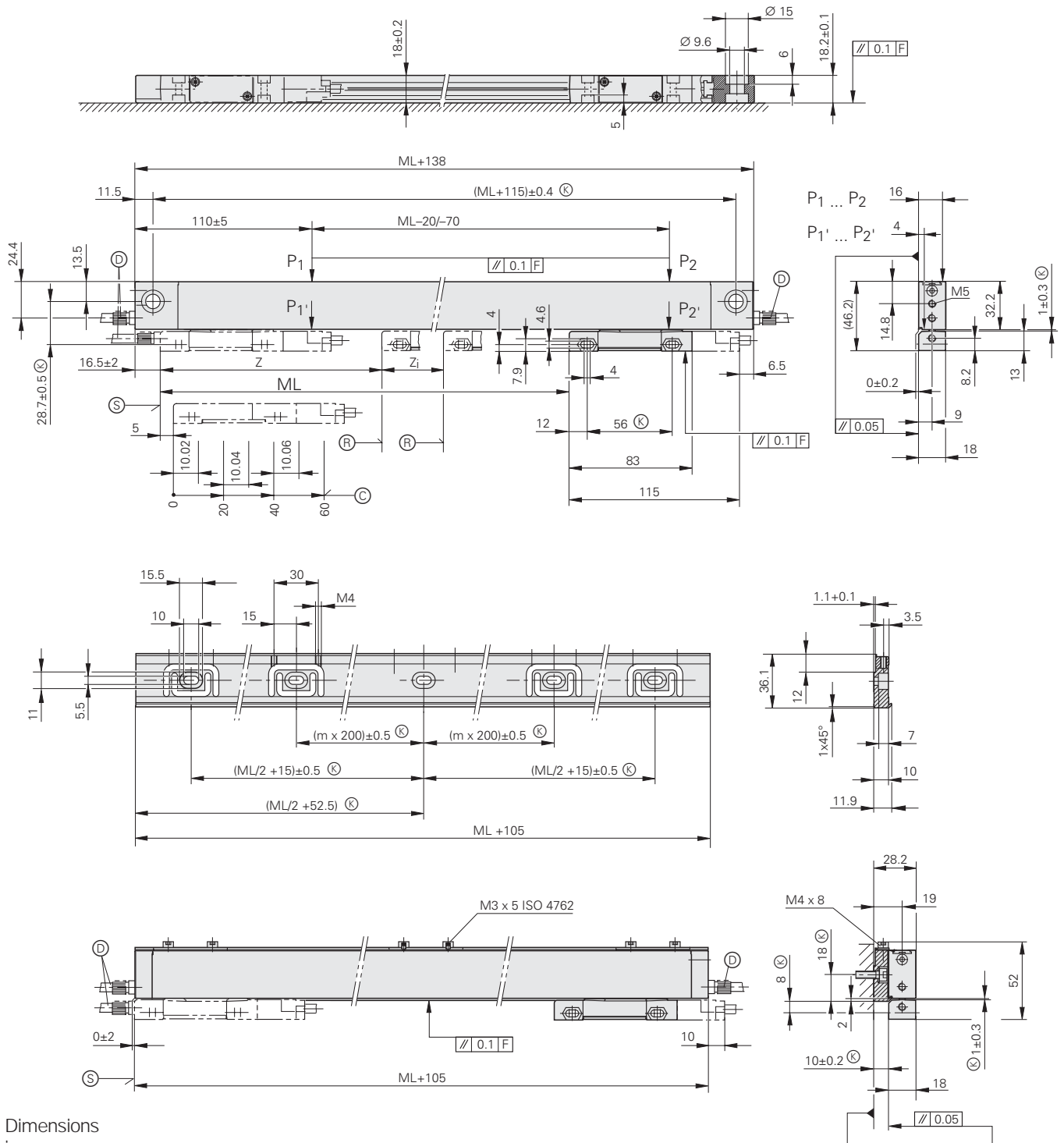

Dimensions
in mm

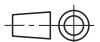

DIN ISO 8015
ISO 2768 - m H

Mounting spar

ML	m
70 ... 520	0
570 ... 920	1
1020 ... 1340	2
1440 ... 1740	3
1840 ... 2040	4

- ⊙ = Without mounting spar
- ⊙ = With mounting spar
- F = Machine guideway
- P = Gauging points for alignment
- ⊙ = Required mating dimensions
- ⊙ = Compressed air inlet

- ⊙ = Reference mark position on LS 406
- Two reference marks for measuring lengths

70 ... 1020	1140 ... 2040
z = 35 mm	z = 45 mm
z ₁ = ML - 70 mm	z ₁ = ML - 90 mm

- ⊙ = Reference mark position on LS 406 C
- ⊙ = Beginning of measuring length (ML)

LS 106

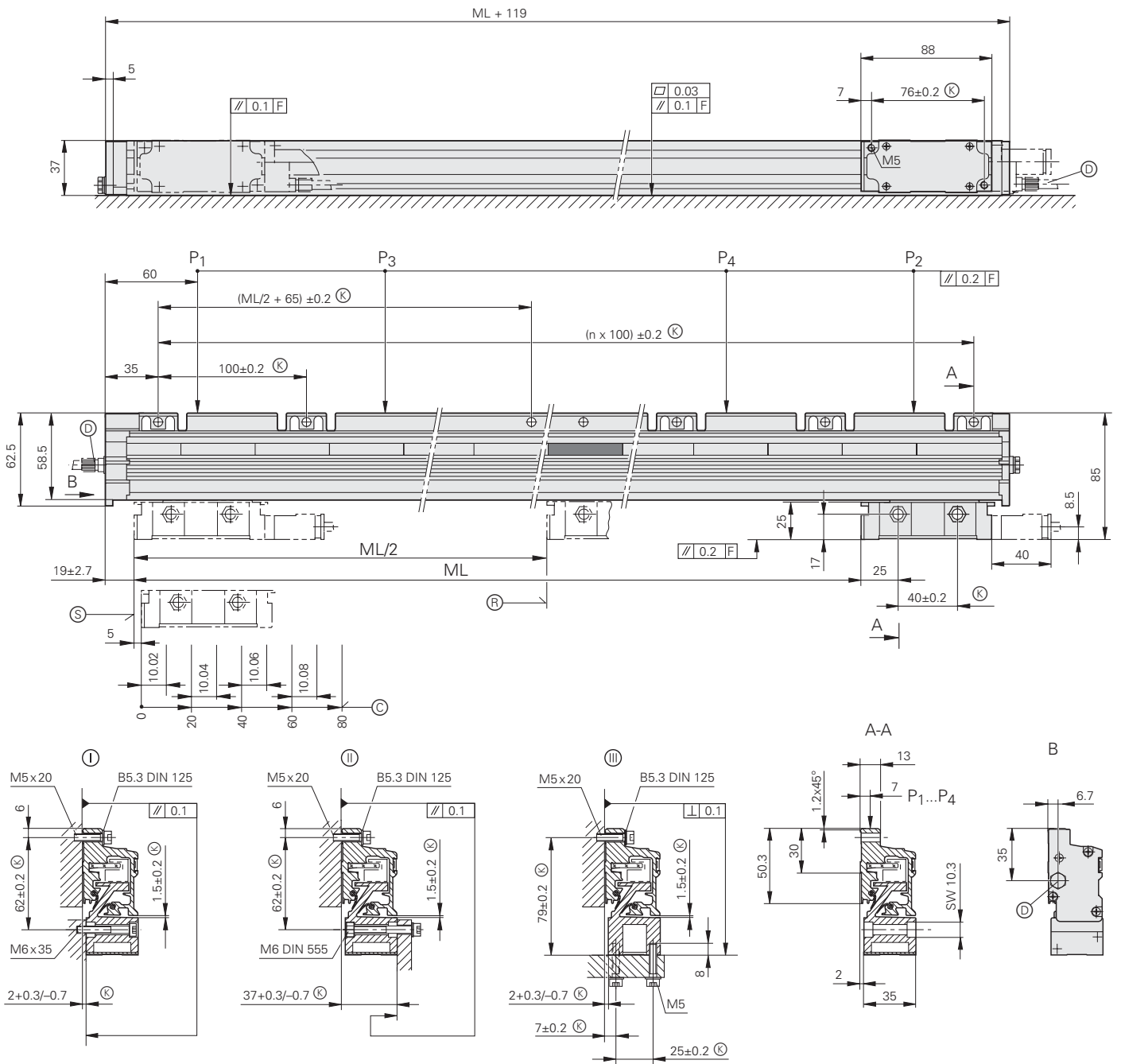

Dimensions
in mm

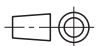

DIN ISO 8015
ISO 2768 - m H

- ⊙, ⊕, ⊗ = Mounting options
- F = Machine guideway
- P = Gauging points for alignment
- ⊗ = Required mating dimensions
- ⊙ = Compressed air inlet
- ⊕ = Reference mark position on LS 106
- ⊗ = Reference mark position on LS 106C
- ⊙ = Beginning of measuring length (ML)

LB 302 up to 30040 mm measuring length (multi-section housing)

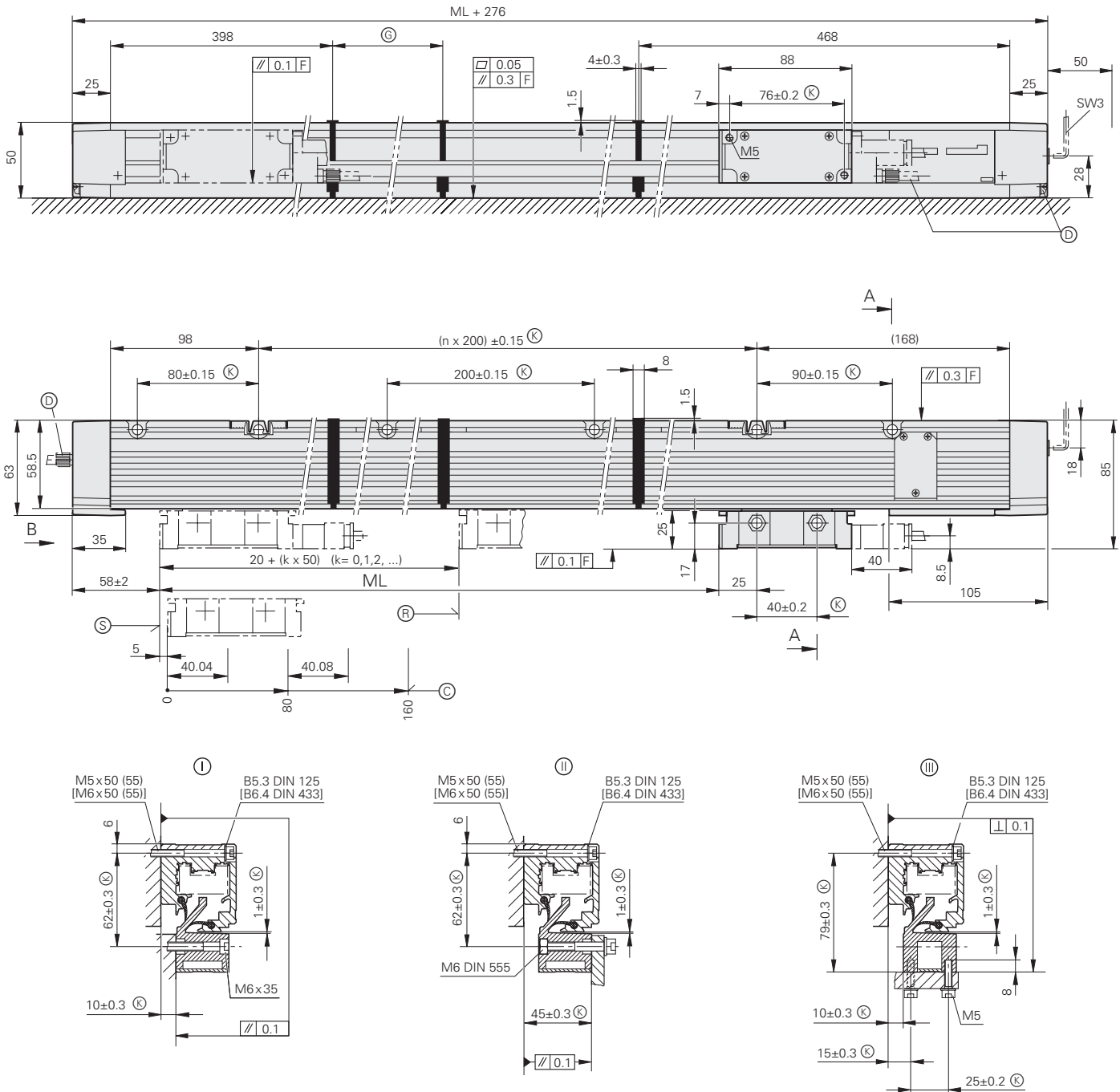

Dimensions
in mm



DIN ISO 8015
ISO 2768 - m H

- ⓪, Ⓛ, Ⓜ = Mounting options
- F = Machine guideway
- Ⓚ = Required mating dimensions
- Ⓢ = Compressed air inlet
- Ⓡ = Reference mark position on LB 302
- Ⓒ = Reference mark position on LB 302C
- Ⓜ = Beginning of measuring length (ML)
- Ⓝ = Housing section lengths
(available lengths 1000, 1200,
1400, 1600, 1800, 2000)

LIM 501

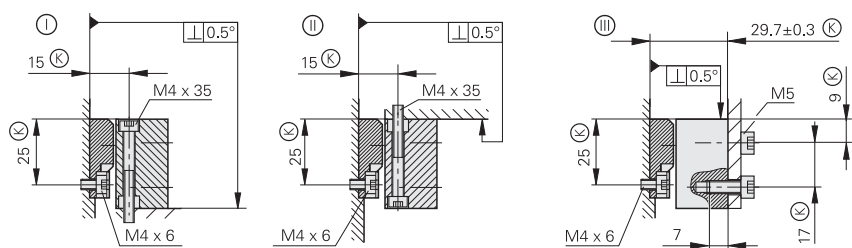
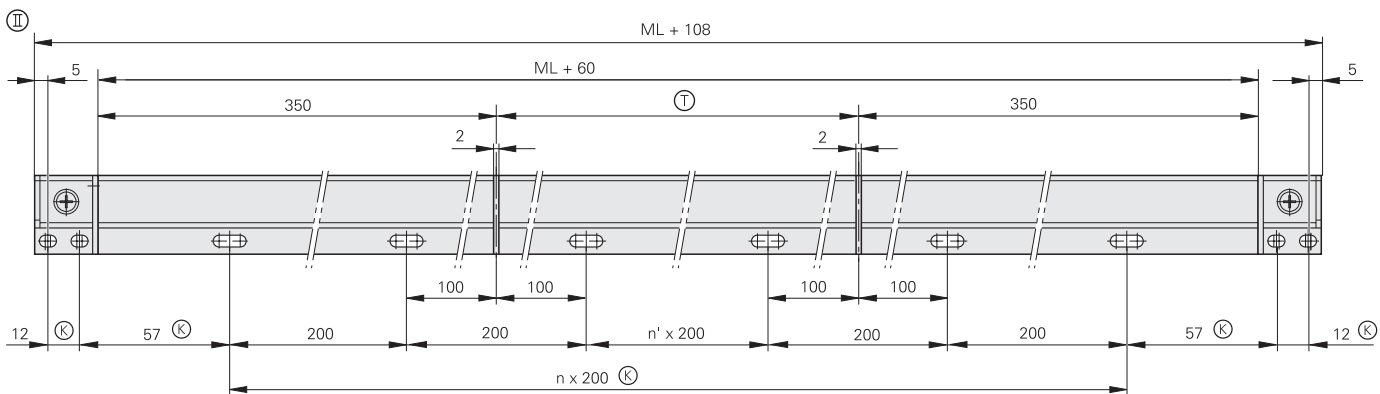
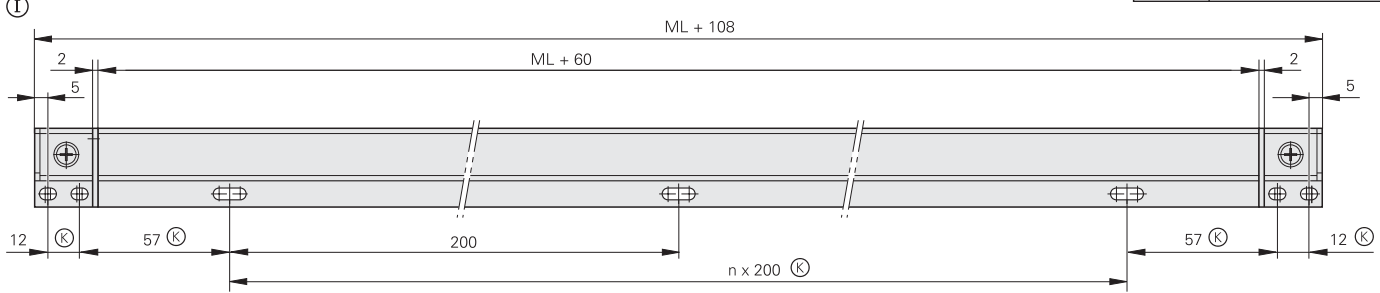
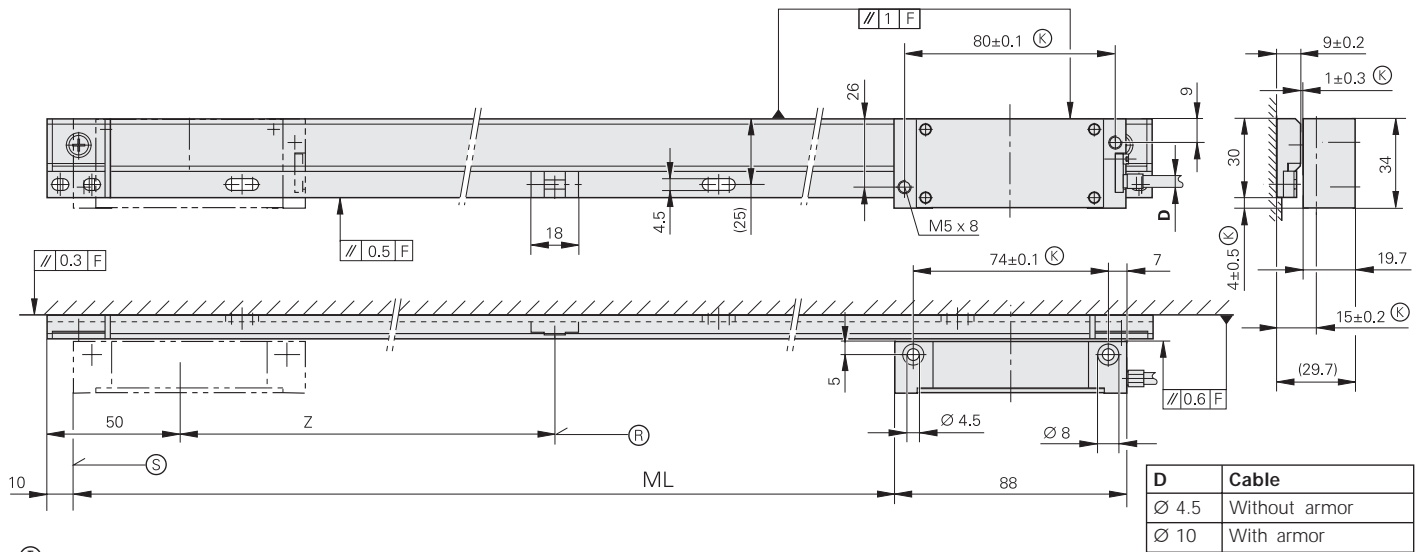

Dimensions
in mm

DIN ISO 8015
ISO 2768 - m H

- ⊙ = Single-section housing
- ⊕ = Multi-section housing
- ⊙, ⊕, ⊗ = Mounting options
- F = Machine guideway
- ⊗ = Required mating dimensions
- ⊕ = Assembled from housing sections (available lengths 1000, 1200, 1400, 1600, 1800, 2000)
- ⊙ = Reference mark position
- ⊙ = Beginning of measuring length (ML)